

Elekta Annual Report 2004/05



Fighting serious disease

Elekta – a comprehensive provider of clinical solutions and information systems for treating cancer and brain disorders

Elekta is an international medical-technology Group, providing advanced clinical solutions and comprehensive information systems and services for efficient and cost-effective high precision treatment of cancer and brain disorders.

Elekta's systems and solutions are used at over 3,000 hospitals around the world to treat cancer with radiation therapy, to diagnose and treat brain disorders as well as to run efficient and effective clinical practices.

All of Elekta's solutions employ non-invasive or minimally invasive techniques and are therefore gentle to the patient and cost-effective, in addition to being clinically effective.



Elekta develops clinical solutions and information systems through close collaborative relationships with customer partners in research and advanced product development. Through these efforts Elekta is addressing the needs of health care systems as well as patients by reducing hospitalization costs and providing

less traumatic treatment options.

Elekta was founded in 1972 by the late Lars Leksell, Professor of Neurosurgery at the Karolinska Institute in Stockholm, Sweden. The company is listed on the Stockholm Stock Exchange since 1994 under the ticker EKTA.

Elekta around the world



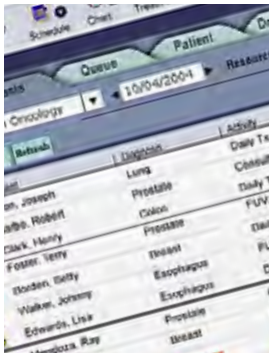

In August, 2005, the market cap of Elekta was over SEK 10 billion (USD 1.3 billion).

The primary markets for Elekta's products are North America and Europe, followed by Asia and Japan.

During fiscal year 2004/05, Elekta's sales (including IMPAC for the full year), amounted to

approximately SEK 3.8 billion, with 1,671 employees at fiscal year end.

Elekta conducts extensive research and development with around 350 qualified team members involved in the product creation process at the company's research centers in Sweden, United Kingdom, USA and Finland.



Contents

Elekta's operations 2004/05	2-3
President's comments	4-5
Vision, values, strategy and objectives	6-7
Elekta's employees	8-9
Elekta – a comprehensive provider	10-11
IMPAC Medical Systems, Inc.	12-13
Customer support	
– Elekta Lifecycle Services	14-15
Innovative and effective clinical solutions	16-27

Financial information

Board of Director's report, incl. IFRS	28-33
Corporate governance, incl. Board of Directors, organization, CEO, Executive Committee and Auditor	34-37
Income statement with comments	38-39
Balance sheet with comments	40-41
Changes in shareholders' equity with comments	42-43
Cash flow statement with comments	44-45
Notes	46-58
Appropriation of profit	59
Audit Report	59

Five-year review, key figures and definitions	60-61
The Elekta share	62-64
Glossary and reader's guide	65

Financial information

Annual General Meeting	September 21, 2005
3-month interim report	September 21, 2005
6-month interim report	December 12, 2005
9-month interim report	March 8, 2006
Year-end report	June 14, 2006
Annual Report 2005/06	September 2006

Other information

For further information about Elekta, please visit www.elekta.com or contact Peter Ejemyr, Group Vice President Corporate Communications, Phone: +46-8-587 254 00, e-mail: peter.ejemyr@elekta.com

Regulatory status of products

This document presents Elekta's product portfolio. Certain products or functionality described may be works in progress or pending regulatory approval for certain markets.

Elekta's Operations 2004/05

Results from operations during the year

- Profit after taxes amounted to SEK 241 M (248). Earnings per share after dilution amounted to SEK 7.67 (7.63).
- Operating profit increased by 14 percent, amounting to SEK 349 M (306) and the operating margin was 11 percent (11).
- Cash flow from operating activities amounted to SEK 408 M (448).
- Order bookings rose 9 percent to SEK 3,558 M (3,262). At unchanged exchange rates order bookings increased by 12 percent.
- Net sales increased 9 percent to SEK 3,152 M (2,900). At unchanged exchange rates net sales increased by 13 percent.

Key data

	2002/03	2003/04	2004/05
Order bookings, SEK M	3,186	3,262	3,558
Net sales, SEK M	2,781	2,900	3,152
Operating profit, SEK M	323	306	349
Operating margin, %	12	11	11
Return on capital employed, %	22	20	20
Cash flow from operations, SEK M	361	448	408
Equity/assets ratio, %	49	46	37
Net debt/equity ratio	-0.58	-0.65	0.05
Earnings per share after dilution, SEK	7.14	7.63	7.67

Significant events during fiscal year 2004/05

- In fiscal year 2004/05, Elekta reinforced its leading position in advanced solutions for radiation therapy. At the ASTRO conference in Atlanta, USA, in October 2004, Elekta clearly demonstrated its leadership in terms of clinical experience with image guided techniques (IGRT). A bibliography on IGRT using Elekta technologies listed no less than 127 presentations and papers.
- In neurosurgery, Elekta continues to set the standard for non-invasive treatment solutions. At AANS in New Orleans, in April 2005, Elekta displayed its fourth generation Leksell Gamma Knife® as well as the revolutionary Elekta Synergy® S, the ideal extracranial complement to Gamma Knife® surgery.

- On April 4, 2005, Elekta acquired IMPAC Medical Systems, Inc. The acquisition value including direct acquisition costs amounted to USD 257 M (SEK 1,812 M). At the time of the acquisition, IMPAC had liquid assets amounting to USD 61 M (SEK 428 M). Joining forces with IMPAC enables Elekta to offer its customers a new broad range of medical IT systems for use in cancer care. Combined, Elekta and IMPAC are able to offer fully integrated solutions centered on image enabled electronic medical records – covering the entire cancer treatment process. The acquisition strengthens Elekta's presence and position in the US market, and Elekta's international sales organization will facilitate sales and further market penetration for IMPAC's systems outside the US.

Order bookings

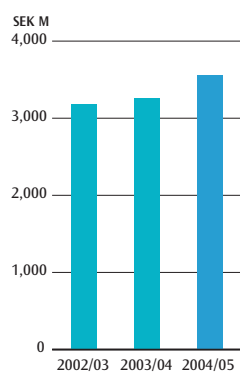

Order bookings continue to grow in line with Elekta's growth objective. In 2004/05 order bookings amounted to SEK 3,558 M, an increase by 12 percent at unchanged exchange rates.

Net sales and operating margin

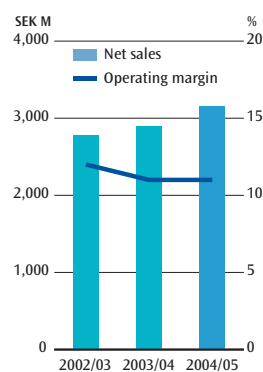

Net sales rose in 2004/05 by 13 percent at unchanged exchange rates to SEK 3,152 M. Operating margin remained at 11 percent, despite a negative currency impact.

Operating profit

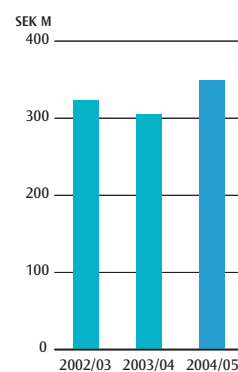

Elekta's operating profit increased in 2004/05 to SEK 349 M. The gross margin declined to 38 percent (39) as a result of changes in product mix.

Capital employed and return on capital employed

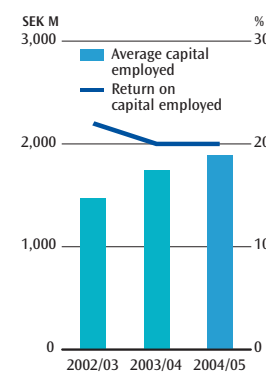

Average capital employed increased as a result of the acquisition of IMPAC in April, 2005. Return on capital employed for 2004/05 was 20 percent.



- In October, 2004, Elekta was chosen as solution partner in UK's largest ever cancer centre PFI (Private Finance Initiative) and, as a first step, was rewarded a contract to provide 10 linear accelerators to equip a new cancer centre at St. James' Hospital in Leeds.
- During the year, Elekta continued to sign preferred provider contracts with large Group Purchasing Organizations (GPOs) in the US, which further strengthens Elekta's market position on the US market. In June, 2004, a contract for radiation oncology solutions and for stereotactic radiosurgery solutions was signed with Consorta. In July, 2004, a contract for radiation

oncology solutions was signed with Premier Purchasing Partners, L.L.P., the group purchasing division of Premier, Inc.

- In January and February, 2005, in accordance with the company's dividend policy, Elekta repurchased 224,900 B shares for a total amount of SEK 50 M. The Board will propose to the Annual General Meeting that these shares be cancelled.
- In April, 2005, Elekta received an order to deliver 10 linear accelerators within a program to multiply public radiation therapy capacity in Venezuela. The order, valued at over SEK 100 M was booked in April, 2005. Two systems were also delivered in the same month while the remaining eight systems will be delivered later this year and in 2006.

Significant events after the end of fiscal year

- On May 1, 2005, Tomas Puusepp – previously head of Elekta's global Sales, Marketing & Service and an Elekta employee for 17 years – assumed the position as President and CEO of Elekta. Laurent Leksell, President and CEO since the inception of the company, instead assumed a new role with full time focus on the Group's strategic development, long-term customer relations and expansion into new markets.
- In June, 2005, in accordance with the company's dividend policy, the Board of Elekta proposed a dividend of SEK 1.60 per share. Against the background of the company's strong financial position, stable cash flow and current capital structure, the Board in addition also proposed a payout of an extra dividend of SEK 5.00 per share.

Earnings per share

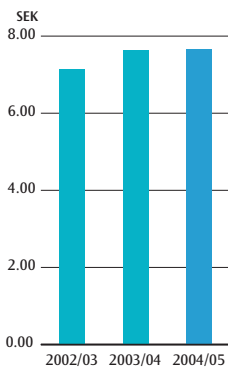

Earnings per share – after dilution through outstanding warrants – continued to increase and amounted to SEK 7.67 for 2004/05.

Currency exposure

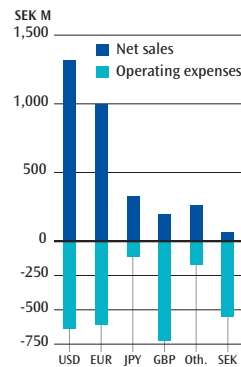

Elekta's sales are primarily in USD and EUR. Costs for oncology products are primarily in GBP, while costs for neurosurgery products are mainly in SEK.

Financial objectives and results

	Objectives for fiscal year 2004/05	Results 2004/05	Objectives for fiscal years 2005/06-07/08
Operating margin, %	10-12	11	14-16 *
Sales growth in local currency, %	10-15	13	10-15
Return on capital employed, %	>20	20	>20
Equity/assets ratio, %	>40	37	—
Net debt/equity ratio	—	0.05	<0.25

*To reach 14-16 no later than for fiscal year 2007/08.

In fiscal year 2004/05, Elekta achieved its financial objectives except for the equity/assets ratio, which was affected by the acquisition of IMPAC Medical Systems, Inc. in April, 2005.

”...ready to take on the next phase in Elekta's development.”

Fiscal 2004/05 was yet another successful year for Elekta. With the acquisition of IMPAC Medical Systems, Inc., we considerably broadened our product range and took a major step toward becoming a comprehensive partner to the health care systems within cancer care and the treatment of brain disorders.

Elekta is growing, both organically and through acquisitions. At the end of the 2004/05 fiscal year, the Group had 1,671 employees in 19 countries. Elekta's loyal, committed and highly knowledgeable employees are a major factor underlying our success, and I would therefore like, first of all, to take this opportunity to thank each and every one of our staff for their dedicated and highly competent work during yet another successful year.

Elekta continues to deliver value to its shareholders through sustainable profitable growth. Order bookings during 2004/05 grew by 12 percent in local currencies. The order backlog at the close of the fiscal year amounted to a record-high SEK 3,493 M. Net sales during the year rose by 13 percent in local currencies.

Despite negative exchange rate movements, operating profit increased by 14 percent to SEK 349 M and the operating margin was 11 percent.

The return on capital employed amounted to 20 percent for the fiscal year and the equity/assets ratio at the close of the fiscal year was 37 percent.

Consequently, we achieved our financial objectives, with the exception of the equity/assets ratio, which was slightly below due to the acquisition of IMPAC.

Continued growth

Looking ahead, we anticipate continued growth, primarily driven by increased demand for clinical solutions and IT systems for cancer care and neurosurgical treatments, underpinned by a steady rise in both incidence and prevalence of cancer. Large areas of the world are considerably underserved by the types of treatment performed using Elekta's clinical

solutions. As the standard of living rises in some of these countries, demand for advanced care will increase. In industrialized countries health care spending is rising rapidly, and care providers are seeking cost-efficient clinical solutions and IT systems that will improve the efficiency of the care process. Elekta is world-leading in all of these aspects.

In all, we assess that the market for Elekta's systems and clinical solutions will grow by 5-10 percent annually. Elekta has substantially reinforced its market position in recent years. We remain the unrivalled market leader in the area of non-invasive radiosurgery and we are the world's second largest supplier of radiation treatment for cancer. Through our pioneering work within intensity modulated radiation therapy and, in recent years, in image guided and stereotactic radiation therapy, Elekta today stands out as the most innovative supplier in the industry – a cut above the rest.

This fact, combined with our – compared to our competitors – much more collaborative and flexible attitude toward our customers, means that we expect to continue to gain market share. We also envisage steadily increasing average sales prices as our delivery mix progresses toward more advanced systems.

In view of this, we are retaining our growth target of 10-15 percent in local currencies.

Higher margins

Our current focus is on increasing the Group's profitability. We have revised our target to reach an operating margin of 14-16 percent no later than fiscal year 2007/08, partly because we expect that future growth will not necessitate cost increases to the same extent. The sales organization and other operations have now reached ideal size and no major investments to increase these capacities are planned for the next few years.

The exception is the decision taken in 2004/05 to invest in a new business system for the entire Group. Over the next

few years, we will be implementing a global ERP system (Enterprise Resource Planning). The reason for this investment is that we need a system that will allow us to grow our sales without having to add additional administrative resources to the same extent. The project is an important investment which we believe will enable considerable cost savings in the future.

A higher proportion of software sales and a change in our geographical mix, with North America rapidly approaching 50 percent of our sales, will also contribute to higher margins.

Steady growth in our installed base of products is also paving the way for increased after-market sales. We anticipate higher volumes and improved gross margins in this area, not least within service operations, which have shown favorable development in recent years.

Our objective of a return on capital employed exceeding 20 percent remains unchanged, while we have replaced the equity/assets target with a debt/equity objective, which is a more internationally recognized indicator of financial stability. The new objective is for a net debt/equity ratio for the Group not exceeding 0.25.

For the fiscal year 2005/06, we forecast sales growth in line with the Group's target of 10-15 percent in local currencies and an operating margin for the full year of 11-13 percent.

At the same time, those who have followed Elekta for some time will be aware that the high value of individual orders and coordination of orders within the framework of investment programs in the health care sector often lead to considerable fluctuations in business volumes between individual quarters.

Offensive investments in R&D

Elekta's success is built to a large extent on many years of successful investment in the research and development of new products, with the result that the Elekta of today has a very strong product portfolio with unique, highly competitive and, in many cases, world-leading products.



“We are increasingly becoming involved in the customer’s entire value chain.”

Our systems for image guided and stereotactic radiation therapy – Elekta Synergy® and Elekta Synergy® S – have been launched with great success and have set new standards for advanced radiation therapy.

Elekta is also continuing to reap success in the field of neurosurgery, and Leksell Gamma Knife® is the most clinically effective and cost-effective method for non-invasive treatment of brain disorders. We have now delivered more than 220 units. During the fiscal year we launched Leksell Gamma Knife® 4C, yet another new generation of this system with substantial improvements that make the work process more efficient and open up new possibilities, particularly in the area of image processing.

IMPAC is also continually improving its product portfolio. In 2004, the new IQ product platform was presented, which will serve as the future base for our range of IT solutions for cancer care.

Our pipeline of new products and new functionality is also very strong. We are offensively investing in research and development in all segments and we will continue to launch clinical solutions and IT systems that improve clinical results, make treatment less traumatic for the patient and enhance the efficiency of health care.

For the foreseeable future, we will therefore continue our R&D investments

at essentially the same levels as today and, taking the higher research amount allocated for IMPAC into account, I assess that these investments during the next few fiscal years will be equivalent to about 8-9 percent of net sales.

A comprehensive partner

Looking strategically ahead on a longer time horizon, it is clear that Elekta will continue its process of transformation from being primarily a supplier of equipment to becoming a comprehensive partner to the health care sector, delivering systems, clinical solutions and services for the entire treatment process within oncology and neurosurgery. This is already in process. We see today that our customers regard us not just as a supplier of technology but rather as a partner for the development and improvement of clinical and administrative processes. Over the course of many years, Elekta has built up a great understanding of our customers’ needs, focusing on the patient and the routines and processes needed to provide optimal patient care. In the same way as we have supplied not just equipment but also expertise and a network of contacts within neurosurgery, our sales efforts in the area of oncology are also assuming more of an advisory role. Our relations with customers are growing more long term and R&D partnerships and user training are becoming more and

more important. We are increasingly becoming involved in the customer’s entire value chain.

A key component of this development was the acquisition in April 2005 of IMPAC Medical Systems, Inc., which means that we can now offer our customers a broad range of IT systems for cancer care applications. The IMPAC acquisition is an important addition to the Group and means that we are ready to embrace the next phase in Elekta’s development.

Our strategy is to continue with Elekta’s transformation and broaden our range of products and services to address a considerably larger market and make an even greater contribution to improving patient care worldwide.

A warm thank you to Laurent Leksell

On May 1 of this year, I had the privilege of assuming the position as President of Elekta, succeeding Laurent Leksell, the longest-serving President of any listed company in Sweden.

I cannot emphasize enough the major role that Laurent Leksell has played in making Elekta what it is today. In his capacity as innovator, instigator, visionary and strategist, he has built Elekta from a small, privately owned, research-based company into a global and world-leading listed medical-technology Group.

I am delighted to be able to continue to work together with Laurent, who in his new position will focus, on a full-time basis, on Elekta’s strategic development, customer relations and expansion into new markets.

I warmly thank Laurent Leksell and all our customers, employees, suppliers, partners and owners, and I eagerly look forward to another exciting year for Elekta.

STOCKHOLM, AUGUST 18, 2005

Tomas Puusepp, President & CEO

A company with a vision...

At the corporate level, Elekta manages its operations by formulating the company's vision, mission, strategy, values, financial objectives and corporate priorities.

In an organization where responsibility for both profitability and operations in general is highly decentralized, these statements provide guidance for managers and employees when making decisions in their daily work.

Vision

“We believe that by working together we can fight serious disease and enhance quality of life”

...reflects the spirit that pervades within Elekta, as well as the value that Elekta's employees see in their work. Elekta's strong customer focus and collaborative approach is the foundation for continuous development of advanced clinical solutions for the benefit of cancer and brain disorder patients all over the world.

Mission

“To always be the first choice”

...summarizes Elekta's ambition to be the company that patients, health care professionals, employees, shareholders and other stakeholders first think of when they seek treatment, a supplier, employment or an investment opportunity.



Elekta Values

Elekta's decentralized organization and decision processes give each manager and employee considerable scope in making decisions regarding his or her work. While this implies a large degree of freedom, it also places substantial responsibility on the Elekta employees. The five Elekta Values function as support for decision-making and as general guidelines in the daily work.

Long-term Customers

When a customer selects Elekta, this is the start of a long-term partnership, with a commitment to ensure that the systems and solutions will continue to facilitate first-class treatment for a long time.

Trust and Reliance

When delivering systems and solutions for treatment of serious disease, trust and reliance are critically important in all stages, internally as well as externally. Patients, clinical specialists and health care providers can all rely on

Elekta's commitment to fast and efficient service and support, as well as the continued enhancement of technology, methods and solutions for the entire treatment chain.

Stretch Boundaries

An international and competitive market requires innovative thinking, openness to new ideas and the courage to think “outside the box”.

Careful with Resources

Sustainable profitable growth requires efficiency in all operations. Optimal resource use helps Elekta, as well as Elekta's customers to reach their goals.

Speed and Performance

The foundation for Elekta's success is the ability to meet customer demands in development and delivery times and at the same time exceed the expectations of customers with respect to quality in performance and results.

Strategy

Elekta's strategy is to provide meaningful clinical solutions, comprehensive information systems and services for improved cancer care and management of brain disorders through:

- Clinically effective and cost efficient technology for precise radiation and minimally invasive techniques.
- Complete information technology solutions and integrated management systems.
- Excellent customer support and value added services across the entire care process.
- Operational proficiency based on Elekta values.

The history of Elekta

The history of Elekta started with the vision of one man, seeing the need for less traumatic solutions for brain surgery. During the 1940s, Professor Lars Leksell developed the stereotactic frame, to be able to position surgical instruments into the brain with great precision.



Elekta's founder, Professor Lars Leksell.

Under the leadership of Laurent Leksell, President and CEO from 1975 to 2005, Elekta developed into a global medical technology Group, leading the development towards more efficient, cost effective and less traumatic treatment of cancer and brain disorders.

As of today, millions of patients all over the world have received minimally or non-invasive treatments using Elekta's solutions for neurosurgery and radiation oncology.

A more comprehensive presentation of Elekta's history is found in "Elekta Milestones", distributed to shareholders with this Annual Report.

Financial objectives

Elekta's objective is to deliver sustainable, profitable growth and the company has established the following financial objectives for the three fiscal years 2005/06 to 2007/08:

- Annual sales growth of 10-15 percent in local currency.
- Operating margin to reach 14-16 percent no later than fiscal year 2007/08.
- Return on capital employed exceeding 20 percent.
- Net debt/equity ratio below 0.25.

Corporate priorities

Within the overall strategy and financial objectives, Elekta annually establishes a number of corporate priorities intended primarily to improve its operations during the coming fiscal year. Each function then adapts its priorities and plans to contribute to these overall priorities. The corporate priorities for fiscal year 2005/06 are:

1. Profitable growth

Focus on sales and marketing, alongside with improved processes and increased internal efficiency, in order to reach the Group's growth and profitability objectives.

2. Time to market

Review and streamlining of the product and technology development organization and processes.

3. IMPAC integration

A speedy but prudent integration of IMPAC's operations where this is beneficial for customers or business operations, securing benefits and achieving the anticipated synergies.

4. Efficiency – organization output factor

Strengthening of the organizational structure and improved processes, in order to achieve higher organizational efficiency.

5. Cash flow

Increased focus and improved processes for working capital management.

A few of the milestones in the history of Elekta:

- 1949** Introduction of Leksell Stereotactic System® prototype
- 1953** First patient treated with a medical linear accelerator
- 1968** Introduction of first Leksell Gamma Knife® prototype for clinical research
- 1972** Elekta Instrument AB founded
- 1983** Elekta establishes first foreign subsidiary in the US
- 1986** First commercial delivery of Leksell Gamma Knife®
- 1990** Delivery of first clinical Multileaf Collimator (MLC)
- 1994** Elekta AB listed on the Stockholm Stock Exchange
- 1997** Elekta acquires Philips radiation therapy division
- 1998** Introduction of Elekta Precise Solutions™ including a digital accelerator with integrated multileaf collimator
- 1999** Introduction of Leksell Gamma Knife® C, with Automatic Positioning System™
- 2002** Elekta becomes the second largest supplier in the world of equipment for radiation treatment of cancer. Elekta starts manufacturing at its subsidiary in China
- 2003** Launch of Elekta Synergy®, the world's first solution for image guided radiation therapy (IGRT). Acquisition of Neuromag Oy
- 2004** Launch of Elekta Synergy® S and Leksell Gamma Knife® 4C
- 2005** Acquisition of IMPAC Medical Systems, Inc.

Highly skilled employees in a multinational organization

Elekta has evolved from a small, privately held business to a public medical-technology Group with global operations and close to 1,700 employees in 20 countries. Elekta's success is highly dependent on the skill and experience of its employees, and subsequently Elekta has a strong focus on retention and development of its employees.

During 2004/05 the number of Elekta employees increased from 1,170 to 1,671 of which 421 were welcomed as new Elekta employees through the acquisition of IMPAC Medical Systems, Inc.



Elekta is a human capital-intensive company with a high level of education of its employees. Close to 60 percent of all employees have an academic degree and more than half of these have university degrees in engineering.

The company is also truly multinational. After the acquisition of IMPAC, 37 percent of the Group's employees are based in the US, followed by the UK with 26 percent. All in all, Elekta has

employees based in 20 countries. This means, among other things, that Elekta provides a challenging and stimulating multi-cultural environment.

With wholly owned subsidiaries in all major markets in the world and several research and development centers in both Europe and in the United States, Elekta has a mature and well scaled organization with each unit focusing on its functional duties across all product lines.

The continued development of Elekta requires retention and recruitment of highly skilled experts in medicine, physics, mechanics, electronics, logistics, sales, marketing, service and administration. To achieve this, Elekta must be competitive on the labor market, offering attractive working conditions and challenging responsibilities.



Merger of corporate cultures

Throughout the acquisition of IMPAC, the human aspects have been in focus. Assessment has been made of IMPAC's corporate culture, evaluating similarities and differences in Elekta's and IMPAC's corporate cultures, knowledge base and experience within different functions. During the gradual integration of the two companies, one focus is to ensure that all employees in the Elekta Group continue to find a challenging and rewarding work environment. The first step in the integration process has been a successful program to merge the sales forces, both in the US and worldwide.

Leadership training

Global companies need to develop leaders who can effectively manage an increasingly complex and fast moving business in which creativity, flexibility and speed are driving competencies. During the fiscal year Elekta finalized its

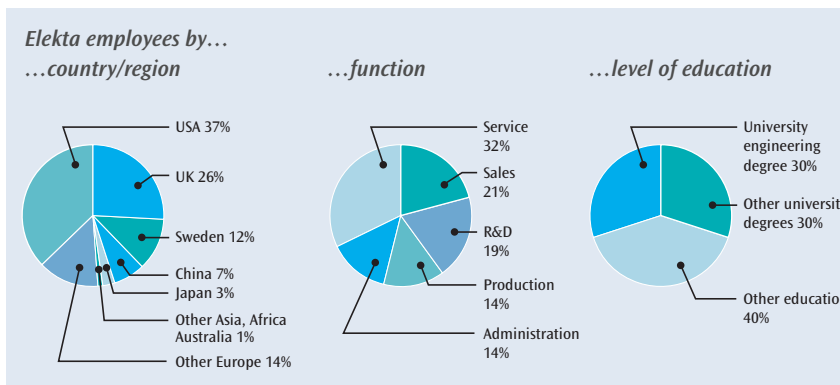

third global three-week Business Leadership Development Program, designed for senior and middle management and other key staff, with the aim to increase effective support for business strategies, objectives and the Elekta Values. Approximately 100 managers and key staff have altogether attended the program during the last two fiscal years.

Management review and development

Elekta takes a long term view of management development and succession. During the year, the company has prepared for future changes by assessing and identifying needs for further strengthening of management capabilities. This review was built on the competency framework of the existing performance management system, mapping the current and future leadership potential as a base for succession planning.



Systematic approach to the work environment

Elekta applies a systematic approach to developing the working environment with the purpose of combining a high quality, financially sound operation with a high standard work environment. A good office and factory environment means that Elekta's employees will have comfort and be effective in their work. The environment should not just be safe and free from hazards, but should also provide a positive experience for the company's employees.

During the year, Elekta Instrument AB (Sweden) implemented a structured approach to ensure a safe working environment, an initiative which will be followed in other Elekta subsidiaries.



Elekta – a comprehensive provider...

From the very beginning, more than three decades ago, Elekta has focused on providing the most effective treatment solutions and improving patient throughput as well as on increasing cost effectiveness.

In recent years, Elekta has developed from predominantly a treatment equipment provider towards a medical technology Group providing systems and clinical solutions spanning the entire spectrum of cancer care and brain disorder treatment.

Enabling clinicians to focus on patients

At the very center of every health care process, is the delivery of effective and efficient treatment at reasonable cost with as little trauma to the patient as possible. Around these “core events” in treating a

patient, every health care program needs to deal with its logistics, in a broad sense. From referral to billing, each and every care provider strives to run operations in a smooth and cost-effective way, enabling its professionals to focus on their core competence – that of curing their patients.

Non-invasive solutions

Almost all of Elekta's treatment solutions are non-invasive, in the sense that no surgical incisions are required, resulting in shorter recovery periods than conventional treatments. Non-invasive treatment is also a gentler alternative for the patient with less negative effect on quality of life. In addition, the reduced demand for after-care minimizes the need for health care services, thus saving valuable resources.

Open architecture and connectivity

The acquisition of IMPAC Medical Systems, Inc. in April 2005, was one important step in Elekta's development, enabling Elekta to offer its customers a new broad range of IT systems for use in cancer care.

Combined, Elekta and IMPAC are able to offer fully integrated solutions centered on an image enabled electronic medical record based on an open architecture and connectivity – covering the entire cancer treatment process, centered on image-enabled electronic medical record (EMR) systems.

Entire spectrum of care

Today, Elekta is one of the world's most comprehensive providers across the

...in the fight against cancer and brain disorders

Elekta develops clinical solutions and information systems to aid in the fight against two groups of serious diseases – cancer and brain disorders. Common to these diseases is that a radical treatment often is needed in the affected area, while surrounding healthy tissue needs to be spared to the largest extent possible.

Cancer is a group of many related diseases that develop when cells in a part of the body begin to grow out of control. Cancer cells replace normal healthy cells and damage the body by impairing the function of a particular organ.

The global burden of cancer continues to increase. Primarily due to an increased average age and improved diagnostic methods, the number of new cases is increasing rapidly. Worldwide, 12 percent of all people die from cancer and in industrialized countries more than one in four will die as a result of this disease. At the same time, develop-

Brain tumors
 – Vascular malformations
 – Functional disorders
 – Leukemia
 – Breast cancer
 – Lung cancer
 – Colorectal cancer
 – Prostate cancer

ment has resulted in increasingly improved cancer diagnosis so that cancers are detected earlier. As a consequence, the possibilities for successful treatment have improved.

In Europe, nearly 2.9 million new

cases of cancer was diagnosed and more than 1.7 million cancer related deaths was recorded in 2004, according to estimates published in Annals of Oncology in February 2005. Overall, lung cancer and colorectal cancer were the most common forms of cancer diagnosed, each representing 13 percent of the total.

Among women, breast cancer was by far the most common form, representing 27 percent of all cases. In men, lung cancer was the most common form of cancer, representing 19 percent of all cases, followed by prostate cancer, representing 15 percent.

The increased average age of the European population means that the incidence of cancer will continue to rise.

The same pattern is evident in the US, where cancer diagnoses are expected to increase to 1.6 million per year by 2010 according to the US National Cancer Institute, a 23 percent increase from the 1.3 million cancers per year in 2000.

entire spectrum of cancer care and neurosurgery. The clinical solutions and information management systems developed by Elekta not only deliver the world's most advanced treatments for cancer and brain disorders, they also help users improve efficiency and productivity. Thus, Elekta provides health care professionals as well as their communities with a more complete and richer understanding of cancer care and the treatment of brain disorders.

Going forward, Elekta plans to continue along this road, gradually transforming the Group from a vendor of equipment and systems, to a full-scale partner in the delivery of the world's most advanced and efficient cancer care and brain disorder treatment.

IMPAC – IT-systems for cancer care page 12-13

Elekta Lifecycle Services – Customer support page 14-15

Precision Radiation Therapy page 16-17

Image Guided Radiation Therapy page 18-19

Stereotactic Radiation Therapy page 20-21

Gamma Knife® surgery page 22-23

Functional Mapping page 24-25

Stereotactic Neurosurgery page 26-27

Radiation therapy in the fight against cancer

Depending on the type of tumor, cancer is normally treated with radiation therapy, chemotherapy, surgery or various combinations of these. Where available, almost half of all patients who are diagnosed with cancer are treated with radiation therapy at some stage of their illness. New advanced, more precise and accurate methods are expected to increase the role of radiation therapy in the future.

Of the three common treatment methods for cancer, radiation therapy is often the least traumatic to the patient and at the same time the most cost-effective.

Brain disorders

Brain disorders are often critical and have a strong negative impact on the patient's quality of life. At the same time, brain disorders are often very hard to treat without risk to the



patient's ability to function.

Tumors that occur in the brain can be divided into two groups, benign and malignant. Among benign brain tumors, vestibular schwannomas, meningiomas

and pituitary adenomas are notable, as they can become life threatening if not treated in time.

Malignant brain tumors are classified as primary tumors and secondary metastases. The latter originate from primary tumors elsewhere in the body.

The incidence of primary brain tumors is about 1,000 per million people. According to the American Cancer Society, between 20 and 40 percent of all cancer patients develop brain metastases.

Vascular malformations in the brain, (arteriovenous malformations, AVMs), are often congenital and often not diagnosed until after causing brain hemorrhage.

Functional brain disorders are diagnosed by observing symptoms such as Parkinsonian tremor or epileptic seizures. Elekta is currently focusing research on such disorders as facial pain (trigeminal neuralgia), epilepsy and Parkinson's disease.

IT-systems for cancer care – IMPAC Medical Systems

IMPAC was founded upon the vision of cancer care providers benefiting from a comprehensive information technology solution designed specifically for oncology. Today, IMPAC systems span the entire spectrum of cancer care and facilitate efficient care at over 2,500 sites worldwide.



IMPAC's full range of cancer care IT-systems help oncology programs save time and money by reducing costs, increasing productivity and providing seamless connectivity to the systems and devices that are integral to the full spectrum of cancer care.

With systems designed to handle the complexities of anatomic pathology, medical oncology, radiation oncology, imaging, clinical laboratory and cancer registry, IMPAC supports the entire team of health care professionals who contribute to the care of the cancer patient. By streamlining the aggregation of information across the entire cancer care team, IMPAC provides a single source of oncology data for analysis and discovery.

IMPAC's strong market position and high customer retention rate is a testament to the ability of a complete oncology IT solution to improve process efficiency and help deliver high quality patient care.



Pathology

Anatomic pathology system that mirrors the workflow in a busy pathology department and streamlines communication of diagnostic results to the oncology cancer care team.

Clinical laboratory

Clinical laboratory information systems that connect to virtually any instrument, making lab results critical to the cancer therapy process available in the oncology EMR.

Medical oncology

Computerized Physician Order Entry – Oncology CPOE – that handles the complexities of chemotherapy ordering and connects to the laboratory and drug dispensing equipment critical to the medical oncology process.

Open connectivity and research driven clinical solutions

As one company, Elekta and IMPAC are able to offer a unique, fully integrated and seamless solution addressing the entire spectrum of the cancer care process. The addition of IMPAC's strong management and software engineering team will create a significant new dimension to Elekta's solutions for cancer treatment, including image guided radiation therapy.

While Elekta will be able to provide its customers with a complete "one-partner" solution going forward, both

Elekta and IMPAC remain firmly committed to an open architecture, multi-vendor software format.

Open connectivity based on industry standards is of great importance for the efficient practice of oncology and is vital for continued improvement of cancer care. Elekta and IMPAC will assume the global leadership in the accelerated development of industry-wide standards and protocols in cancer care in general and in radiation oncology in particular.



IMPAC – An Elekta company

In April, 2005, Elekta acquired IMPAC Medical Systems, Inc.

Founded in 1990, IMPAC is the world's leading provider of oncology management software with more than 2,500 systems installed in 56 countries, including at 43 of the top 50 US cancer hospitals.

In North America, IMPAC's systems are installed in over 1,300 oncology centers, over 1,100 cancer registry operations and over 400 pathology laboratories. Installed sites span virtually every environment, including physician offices, freestanding centers, community hospitals and university teaching hospitals. Local area network and wide area network installations range in size from five to more than 500 workstations. An estimated 25,000 health care workers interact daily with IMPAC products to document encounters with more than 50,000 cancer patients.

More information about IMPAC can be found at www.impac.com.



Radiation oncology

Image-guided treatment management systems that connect radiation therapy planning, imaging and delivery equipment to a comprehensive oncology chart – regardless of manufacturer.

Medical imaging

Image management that stores and manages diagnostic, planning, reference and setup images as part of the therapy process and provides a complete picture of patient care.

Cancer registry

Cancer registry system that not only meets regulatory reporting requirements, but also provides ready access to the data required to effectively review, analyze and ultimately improve clinical outcomes.

Practice management

Core business functionality – scheduling, authorizations, charge intelligence and accounts receivable management – that is optimized for oncology and fundamentally integrated with a specialized oncology EMR.

New IQ platform

To further improve IMPAC's contribution to the evolving spectrum of cancer care, a new IQ product platform was recently introduced. The



platform is built upon a completely new architecture and interface that will ultimately support IMPAC's entire oncology IT solution.

The first product of the IQ series introduced was MOSAIQ™, an oncology focused, image-enabled electronic medical record (EMR) that will support the needs of oncology programs into the next decade. MOSAIQ was built upon a new underlying architecture, incorporates a new user experience and includes advanced functionality to support adaptive radiotherapy, oncology PACS and advanced chemotherapy treatment.

The second member of the IQ series intro-



duced was ANALYTIQ™, IMPAC's new data visualization and analysis tool targeted at clinical and financial outcomes reporting.

Lifetime commitment to continuous improvement – Elekta Lifecycle Services

Elekta's promise is to help clinics not only to face today's health care challenges but to excel on a daily basis.

Elekta Lifecycle Services is developed to ensure peak performance and uptime throughout the life of Elekta treatment systems and promote overall patient satisfaction.

Elekta Lifecycle Services include the industry's most comprehensive customer support programs – from site planning and monitoring to intelligent device management and clinical application training.



Smoothing patient flow

Elekta Lifecycle Services are fine-tuned to reduce unplanned stops, eliminate clinical interruptions, deliver consistent treatment quality and enable more treatments per day. Elekta offers customized Customer Service & Support Programs, a range of on-demand services and Elekta IntelliMax™ that manages, intelligently monitors and service devices for maximum clinical availability and financial performance.

Improving clinical effectiveness

By taking advantage of the latest technology and clinical developments, modular upgrades, enhancements and accessories, Elekta can help the clinic make the most of the resources already available. For the clinic, this means shortening the length of stay, reducing costs per patient and extending equipment lifetime.

Ensuring staff competence

Elekta is committed to helping customers feel confident in the use of the equipment, in order to achieve the highest clinical result. Elekta offers clinical training in collaboration with leading hospitals, comprehensive on-site application training for confidence in clinical practice and technical training that helps the clinic optimize the management of the Elekta equipment.

Improving financial performance

Elekta Lifecycle Services help increase the efficiency of planning and administration to boost revenues and lower cost per patient. With Elekta, the clinic can for example count on site planning, marketing programs and obsolescence programs that proactively upgrade computer equipment and software.

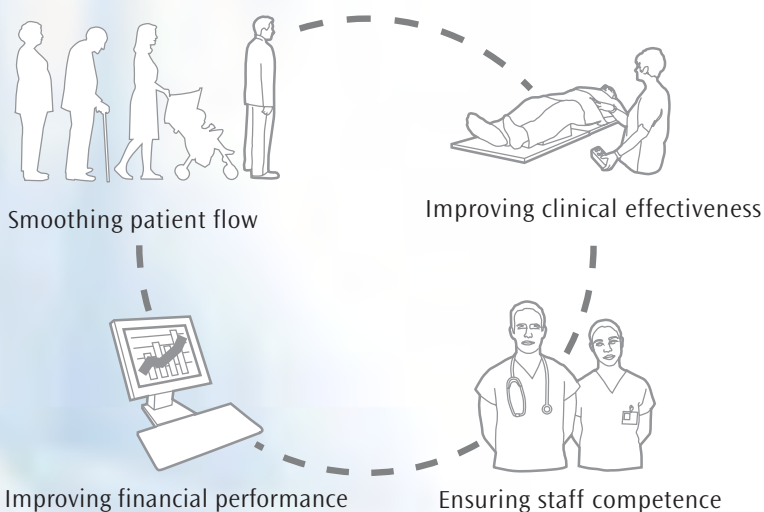



Elekta IntelliMax™

To further enhance speed and performance in Elekta's service operations, an intelligent device management system – Elekta IntelliMax™ – was introduced during the summer of 2004, making it possible to remotely monitor Elekta's linear accelerators.

Elekta is the only company providing a fully digitally controlled radiation therapy equipment. This means providing rich, detailed operational data in a way which is not possible with conventional linear accelerators.

With Elekta IntelliMax, real-time monitoring detects any deviation so that informed, proactive service and management actions can be taken quickly to radically decrease downtime and eliminate the need for service interruptions.

Education & Training

Elekta Lifecycle Services include comprehensive training programs. These programs offered by Elekta are designed to make the clinical staff confident and proficient in the use of their Elekta equipment. Lectures combined with hands-on experience provide caregivers with specialized knowledge, required for correct and efficient treatment of patients.

The educational programs offered by Elekta are also targeted towards more experienced users. Refresher and Advanced courses, as well as supple-

mentary on-site training provide staff with additional competence.

As equipment is upgraded with new technology or when new techniques are introduced, Elekta ensures that the customer receives adequate training provided by specialists. Elekta's training programs are intended for clinicians, physicists, technicians and other hospital staff, working with Elekta products in their daily practice. To date, more than 2,500 clinicians have participated in Elekta's training programs.



Elekta Lifecycle Services™ include three different types of education and training programs:

- **Clinical training**

Training in the clinical use of Elekta equipment in collaboration with leading hospitals.

- **Applications training**

Training of staff operating the equipment on a daily basis. These courses are based on practical hands-on training, provided by experienced instructors.

- **Technical training**

Training in managing the whole lifecycle of Elekta equipment for engineers and technicians.

The programs are divided into three steps covering the equipment's lifecycle:

- **Introductory**

Preparatory training prior to installation.

- **Start-up**

On-site training to secure fast and safe start-up, to provide confidence in clinical use.

- **Advanced**

Supplementary training and refresher courses providing staff with additional specialist competence.

Precision Radiation Therapy

Radiation therapy is rapidly developing towards increasingly refined treatment methods. The goal is to achieve higher precision, with higher doses in the target area and less exposure to surrounding healthy tissue.

Elekta has for decades worked closely with cancer centers around the world to develop a range of products which are capable of delivering high quality radiation therapy to patients. This close collaboration with clinical partners has ensured that functionality and efficiency of Elekta products meet the demanding needs of today's busy clinics.

The challenge to every clinic is to keep pace of new technologies, improve treatment accuracy and increase workflow efficiency. By taking an open systems approach, providing support throughout the lifecycle of the product and providing a range of upgrade options across the product range, Elekta has led the drive to help clinics meet these challenges. This



philosophy ensures that Elekta's linear accelerators achieve their full potential over years to come and that clinics are equipped with the flexibility to evolve and meet the demands of current and future radiation therapy. Elekta's philosophy of providing an open system architecture, also facilitates integration of Elekta's solutions with third party software and equipment.

Pioneering the transition to IMRT

A key ongoing development in radiation therapy is intensity modulated radiation therapy (IMRT). This is a further

development from conformal radiation therapy, a three-dimensional technique using multiple fixed beams of radiation or sequential multiple arc rotational beams to limit the dose to critical organs and healthy tissue. With the IMRT technique, the beam intensity is also varied (modulated) across the treatment field. Rather than being treated with a single, large, uniform beam, the patient is treated with many very small beams; each of which can have a different intensity.

By initiating an international IMRT Consortium as early as 1995, consisting of nine highly renowned centers of radiation therapy, Elekta has been a pioneer in clinical and technical solutions for IMRT. This multicenter cooperation, which is still ongoing, has resulted in a large number of scientific articles and has provided Elekta with advanced knowledge that forms the foundation for current and future product development. Today Elekta is a leading supplier of advanced IMRT technology.

Elekta Precise Treatment System™

Elekta Precise Treatment System™ was conceived and designed as an integrated system to ensure that the performance parameters for a wide range of radiation therapy techniques and advanced applications, such as IMRT, are easily achieved.

The precision of beam delivery, combined with the accuracy of patient positioning on Precise Table, provides speed, accuracy and high resolution. The fully integrated Desktop Pro™ control system streamlines the whole process by providing fast and easy access to patient and treatment data.

Optimized for rapid delivery of PreciseBEAM® IMRT, this system has excellent dose accuracy during the delivery of low dose sequential IMRT fields and rapid beam start-up, through accurate and stable beam control.

Elekta also offers iViewGT™, an advanced portal imaging system which can register the patient's position in relation to the radiation field during treatment.

PrecisePLAN® is Elekta's treatment planning system addressing the clinical situations faced daily, delivering practical 3-D and 2-D solutions, combined with the ability to plan advanced techniques such as IMRT. The system provides real-time interactive 3-D presentation and manipulation for all variations of beam placement and enables accurate and comprehensive dose calculation.

Elekta Precise Treatment System is a robust and reliable system designed for high intensity day-to-day clinical use.

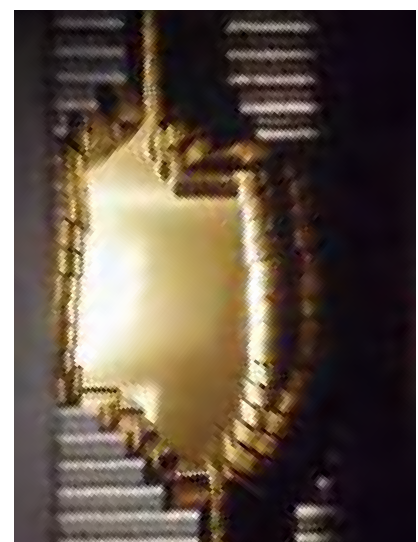



Radiation therapy with the linear accelerator

A linear accelerator produces a radiation beam of either electrons or high energy X-rays. The beam is shaped to match the tumor shape and the patient is positioned to ensure that the beam is directed at the tumor.

In the majority of cases, radiation therapy is given as fractionated treatment, meaning that the patients receive a daily dose of radiation five days a week for six to seven weeks. At each daily treatment, the radiation beam from the head of the linear accelerator is rotated around the patient at different angles so that the entire tumor receives an optimal radiation dose.

The geometry and intensity of the radiation field is adjusted to the tumor's size and shape and also to the type of cancer that is treated. The treatment beam is shaped with a multileaf collimator (MLC) that functions much like the aperture on a camera.

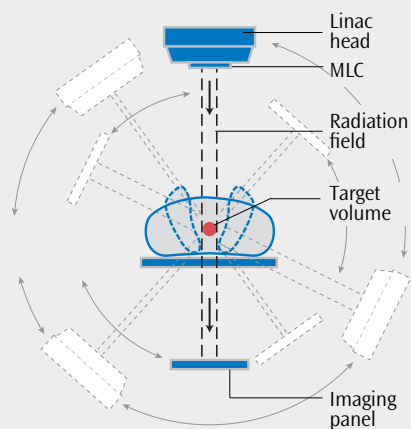

“Our major concerns were equipment reliability, the manufacturer’s commitment to continuing research and development and its willingness to invest their personal efforts and resources into our center to make us successful and keep us at the technical edge where we wanted to be as a teaching institute.



Elekta scored very high in all these areas. We were impressed by the company’s growth, its technical innovation and capacity to move products to market, and reports of equipment reliability. Elekta’s commitment was evident up and down the line, from the corporate office to the Elekta people in India. Elekta has done everything, and continues to do everything, necessary to make us as successful as we are.”

Ron Gottsegen, Administrative Director
Amrita Institute of Medical Sciences and Research Centre (AIMS) in Cochin, Kerala, India.

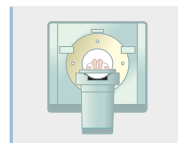

Image Guided Radiation Therapy

Today's advanced methods in radiation therapy makes it possible to deliver conformal and intensity modulated radiation fields. This in turn, makes it increasingly important to address the uncertainties arising from the motion of internal organs and daily patient set-up.

Although radiation therapy has been used to treat cancer for nearly a century, the ability to deliver a precisely targeted dose is still relatively new. With patients first imaged at one time and place, then moved and treated at a different time

4D Adaptive™ IGRT, basic workflow:



Patient has a planning CT-scan

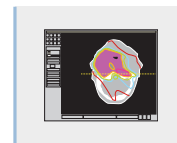

Treatment is planned

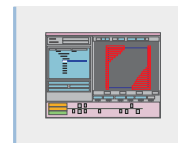

Prescription data and CT image data exported to Elekta Synergy® and Desktop Pro®

and place, the ability to achieve highly accurate dosage delivery has until recently been limited.

Already in the late 1990s, Elekta

initiated research on how to integrate high-resolution imaging on the linear accelerator, a paradigm now labeled image guided radiation therapy (IGRT). This pioneering work led to the introduction of Elekta Synergy® in 2003-04, the world's first radiation therapy treatment platform that allows clinicians to both image and treat patients in the same location. The result is unmatched clinical confidence, enabling more aggressive treatment of tumors while minimizing damage to surrounding healthy tissue.

Elekta supplies the world's most advanced IGRT technology and the company has a recognized leadership



Elekta Synergy®

Elekta Synergy® is the first linear accelerator with integrated equipment for high resolution 3D imaging. This advanced system will acquire and reconstruct the 3D image data on the target, as well as surrounding critical structures, as a whole volume with a single gantry sweep. This produces an image with CT-like contrast but without the slicing artifacts usually associated with fan-beam acquisition. The precision can be reproduced accurately with image quality that has the uniform spatial resolution associated with a MR image, with isotropic sub-millimeter resolution.

Elekta Synergy does this by using an innovative X-ray volume imaging (XVI) technology that is integrated directly into the treatment system itself. This means that routine 3D volume imaging of a tumor can now be performed immediately prior to treatment, decreasing the risk of

error due to movements of the tumor or internal organs. In addition, since the patient does not have to be moved from an imaging device (eg. MR, CT) to the radiation therapy treatment machine, the risk of errors from re-positioning the patient will also be reduced.

Elekta Synergy takes full benefit of the sub-millimeter isotropic resolution offered by Cone-beam Computed Tomography, visualizing internal structures down to voxel level (dimension of 3D volume that is similar to a 2D pixel). This level of detail has never been readily available to radiation oncologists and is not available on competitive equipment. Collecting such a large volume of data in one acquisition results in significant time savings – critical in a situation where the patient is to remain in the treatment position.

Elekta Synergy can operate in PlanarView™ (2D images), MotionView™ (sequential images)

and VolumeView™ (3D images). These images also make it possible to see soft tissue such as tumors and sensitive organs.

By directly addressing the challenges of organ motion and set-up errors, Elekta Synergy promises to revolutionize the way radiation therapy is implemented.



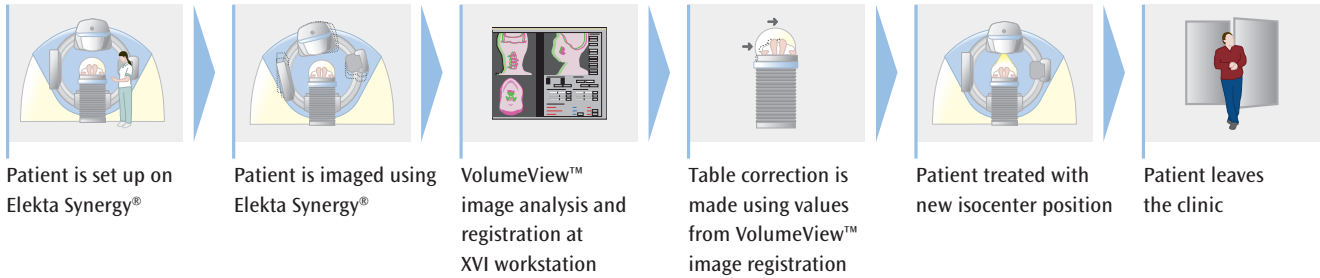

in clinical experience with image guided techniques.

With Elekta's concept 4D Adaptive™ IGRT and 3D volumetric imaging on Elekta Synergy (VolumeView™), clinicians can visualize soft tissue details in any area of the body. This unique functionality offers two potential benefits:

- Patient outcomes – the ability to minimize side effects of radiation therapy by reducing the margins previously set to account for uncertainties in target dimension, location and movement.
- The potential to adopt dose escalation and hypofractionation regimes with the confidence that a 3D plan will be delivered as an accurately targeted 3D treatment.

Elekta's pioneering research and development in IGRT was done in close collaboration with world-leading cancer centers, ensuring the features, functionality and efficiency to meet the clinical needs.

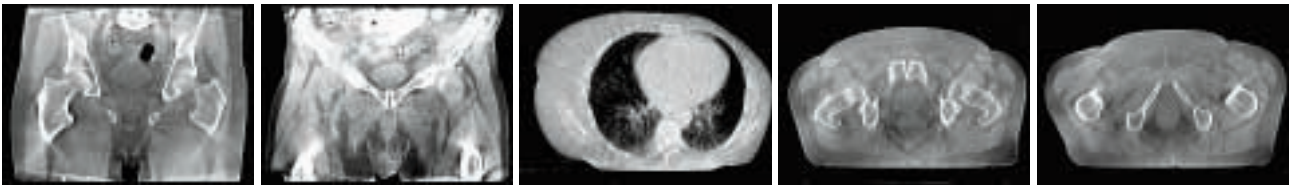

“Synergy has come out of years of research. It’s a product that was driven by an understanding of the challenges associated with being precise in radiation therapy. This technology has a strong role in allowing us to address set-up error issues and organ motion issues on the interfraction basis.”



David Jaffray, Ph.D.
Princess Margaret Hospital, Toronto, Canada

Stereotactic Radiation Therapy

The experience from users of Elekta image guided and stereotactic systems show the need for, and the value of, specialist systems for specialist treatments. In collaboration with its clinical partners, Elekta has developed a solution that will meet the specialists' need for stereotactic radiation therapy (SRT).

Intensity modulated radiation therapy (IMRT) and image guided techniques have increased the range of indications suitable for treatment with radiation therapy. Its full potential, however, has been limited by the inability to achieve the level of conformity required for small, irregular targets located close to critical organs.

Clinical images courtesy of the Netherlands Cancer Institute (NKI), Amsterdam, the Netherlands.

Bridging the gap between radiosurgery and radiation therapy.

Elekta has over 30 years of experience in stereotactic techniques through its use in the practice of stereotactic neurosurgery with Leksell Stereotactic System® and radiosurgery with Leksell Gamma Knife®. The development of solutions for stereotactic radiation therapy is a result of Elekta's commitment to cross-fertilize the areas of radiation therapy and neurosurgery. It is also bridging the gap between Leksell Gamma Knife and the linear accelerator.

To expand the use of stereotactic radiation treatment outside the brain, either in one single fraction through stereotactic radiosurgery (SRS) or as multiple-fraction stereotactic radiation therapy (SRT), demands greater accuracy

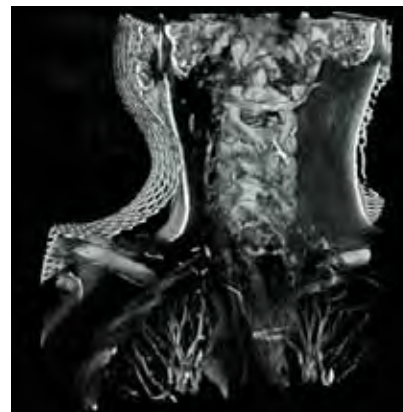

in targeting and limitation of organ motion. Localization and immobilization devices, together with image guidance systems, play a key role. Once the target has been accurately localized the delivery of the radiation must be highly

Elekta Synergy® S

Elekta Synergy® S is the most advanced linear accelerator supplied by Elekta and the ideal extra-cranial complement to intracranial stereotactic radiosurgery with Leksell Gamma Knife®. Beam Modulator™*, the fully integrated fine resolution multileaf collimator, is optimized to provide tight conformance in critical regions such as head-and-neck, while still retaining a maximum field size suitable for most standard radiation therapy treatments.

The system uses kilovoltage X-ray volume imaging (XVI) to image the target and critical organs (both soft tissue and bony structures) in three dimensions through volume imaging mode (VolumeView™). Pioneered by Elekta, this technology images the patient in the treatment position at the time of treatment.

Elekta Synergy S brings together technologies to enable ultra-high target conformance and opens up the potential for SRT.

Stereotactic Body Frame® enables the coordinates of a target to be localized during planning and treatment. More accurate localization enables conformal treatments such as IMRT to be performed with greater precision and pro-

vides the necessary conditions for dose escalation and hypofractionation.

Active Breathing Coordinator™ addresses the localization challenges associated with breathing motion and provides a stable and reproducible target position. It has particular application for precision treatment in the thorax or upper abdomen.

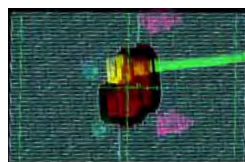

* Beam Modulator™ contains technology developed by Deutsches Krebsforschungszentrum (German Cancer Research Center) in Heidelberg (DKFZ), and is used under license.

precise. Elekta's system for stereotactic radiation therapy therefore integrates high-resolution beam-shaping, stereotactic target localization, organ motion limitation and a unique image guided registration system based on 3D volumetric imaging, integrated and optimized for stereotactic radiation therapy.

The greater accuracy offered by stereotactic methodology facilitates hypofractionation, a key objective of stereotactic radiation therapy, which means radiation therapy given in only a few fractions (treatment occasions). The improved target localization and patient positioning combined with organ stabilization, enables conformal treatments such as IMRT, dose escalation and hypofractionation to be performed with greater precision, promising clinical benefits.



Stereotactic center of excellence choosing dedicated solutions

In February, 2005, the Swedish Cancer Institute in Seattle, Washington, signed a strategic partnership and technology application agreement with Elekta. Under the agreement, the institute will acquire up to four Elekta linear accelerators equipped for image guided and stereotactic radiation therapy.

With the addition of Elekta Synergy® S, the Swedish Cancer Institute will have the tools necessary to become a stereotactic center of excellence using dedicated disease-specific solutions: Elekta Synergy S for extracranial applications and Leksell Gamma Knife® for intracranial radiosurgery.



Todd Barnett, M.D.,
Radiation Oncologist and Medical Director,
Swedish Cancer Institute, Seattle, Washington, USA

“Our medical oncologists and surgeons want better treatment options for patients with liver metastases, paraspinal metastases and even pancreatic primary tumors – targets where surrounding structures are very sensitive, and where we could perform some highly focused treatments.”

Gamma Knife[®] surgery

Gamma Knife[®] surgery represents the cutting edge in high-precision radiation treatment and the gold standard in non-invasive brain surgery. Replacing the saw and the scalpel with highly focused radiation beams which produce the desired biological effect at a precisely predetermined target in the brain, the patient can often leave the hospital the same day as the treatment.

Since its introduction, Gamma Knife surgery has revolutionized the treatment of brain disorders. Today, this treatment is offered by hundreds of leading hospitals and clinics around the world. Around 40,000 patients undergo Gamma Knife surgery every year, and this unique procedure has earned an outstanding scientific track record with thousands of peer reviewed articles on treatment efficacy, improved quality of life for patients and cost efficiency. In fact, no other alternative treatment in this field has gained greater clinical acceptance.

Gamma Knife surgery is a non-invasive method for treating brain disorders. It is defined as the delivery of a single, high dose of radiation to a small and critically located intracranial volume through the intact skull. After Gamma Knife surgery, the patient normally leaves the hospital the same or the following day, making it a very cost effective alternative to open surgery.

The extreme precision of Leksell Gamma Knife[®] makes it possible to administer a high radiation dose to the diseased area, with minimal risk of damaging healthy tissue. Leksell Gamma Knife is successfully used for treatment of metastases and other malignant tumors, benign tumors, vascular malformations as well as functional disorders such as chronic facial pain (trigeminal neuralgia). Studies are also being conducted on epilepsy, Parkinson's disease and on eye disorders, showing that Gamma Knife surgery can reduce the main symptoms in advanced glaucoma

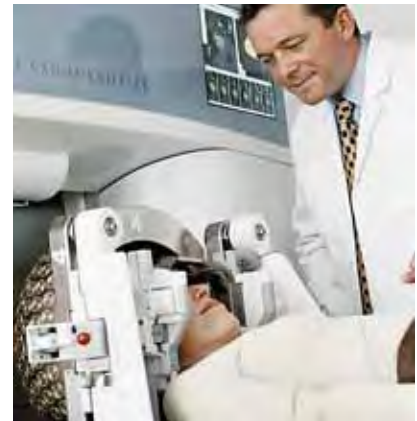

even when conventional therapy fails.

The largest and fastest growing indication for Gamma Knife surgery is brain metastases. It is estimated that 20 to 40 percent of all cancer patients develop metastases in the brain. As the oncologists achieve higher success rates in curing or controlling the primary cancer, it becomes increasingly important to address the metastatic tumors – in a way that preserves the patient's quality of life.

Leksell Gamma Knife[®] 4C

Gamma Knife[®] surgery allows the neurosurgeon to achieve unsurpassed treatment accuracy and conformity. Combined with the most user-friendly treatment planning system available, Leksell Gamma Knife[®] is considered as the reference method in radiosurgery.

The fourth generation, Leksell Gamma Knife 4C is a complete system which comprises a dedicated treatment planning software – Leksell GammaPlan[®] 4C – and an advanced treatment technology including the robotic Automatic Positioning System™.

This system digitally integrates diagnostic images, treatment planning and dose delivery into a single, seamless information flow.

Leksell Stereotactic System[®] plays a key role in the success of Gamma Knife surgery. Leksell[®] Coordinate Frame is easily secured to the patient's head and gives the reference for the stereotactic coordinate system. It ensures that the head is securely supported throughout the

whole procedure. A selection of exchangeable components provides maximum flexibility when attaching the frame. The stereotactic technique makes it possible to accurately map the brain in three dimensions, then to precisely locate the target structures deep within the brain.

The treatment plan produces a number of isocenters based on the coordinates defined by the stereotactic coordinate system. These isocenters are then irradiated, ensuring that the target is covered precisely. By using Automatic Positioning System to position the patient's head, even the most complex plans can be easily administered.

The accuracy for Leksell Gamma Knife 4C is guaranteed to be better than 0.5 mm.

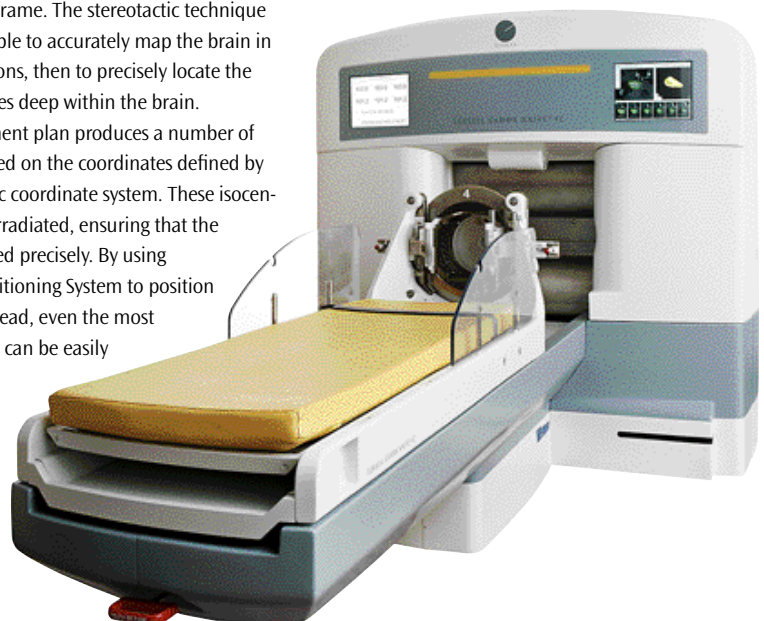

“I chose the Gamma Knife”

In 2004, after several months of fatigue, headaches and vision problems, physicians discovered that skater Scott Hamilton, four-time U.S. National Champion, four-time World Champion and Olympic Gold Medalist, had a craniopharyngioma. This is a relatively rare, non-cancerous brain tumor, that yet is hard to treat and normally has an uncertain prognosis.

With conventional surgery too risky, Hamilton turned to Gamma Knife® surgery, performed at the Cleveland Clinic Gamma Knife Center by Dr. Gene Barnett and Dr. John Suh on December 13, 2004.

“I decided I wanted to take the safest route, that I had too much at stake, especially with a new family,” says Scott Hamilton. “I chose Gamma Knife surgery for the accuracy and efficiency.”

For Hamilton, the worst part of the operation actually occurred before the



actual treatment. “I had to have a brain biopsy, which was the scariest part” he said. “I knew that whatever came after that would be a walk in the park. I remember waking up in the recovery room, seeing it was 10:20 and knowing where I was and who I was. That was the greatest feeling in the world.”

On the day of the surgery, physicians explained to him and his wife Tracie the

day’s activities, and then attached the frame. After the planning was completed, treatment required 25-30 minutes.

Hamilton praises the gentleness of Leksell Gamma Knife treatments. “I felt fine the next day,” he adds. “And that night, Tracie and I celebrated with our anniversary dinner.”

“Some people say a glass is half-full or half-empty. I have a glass-and-a-half.”

Radiosurgery with Leksell Gamma Knife®

With very few exceptions radiosurgery with Leksell Gamma Knife® is given in one single fraction under local anesthesia.

During the surgery, 201 radiation beams from Cobalt 60 sources converge with high accuracy on the target to be treated.

The hemispherical collimator helmet focuses the beams of radiation onto the surgical target. The patient’s head is held in place using Leksell® Coordinate Frame.

The beams converge in what is called an isocenter where the cumulative radiation intensity becomes extremely high. Each individual beam has low intensity and therefore does not affect the tissue through which it passes on its way to the target.

By moving the patient’s head in relation to the beams’ isocenter, the radiation dose can be optimized in relation to the shape and size of the target. In newer generations of Leksell Gamma Knife, these minimal movements are accomplished using the robotic Automatic Positioning System™.

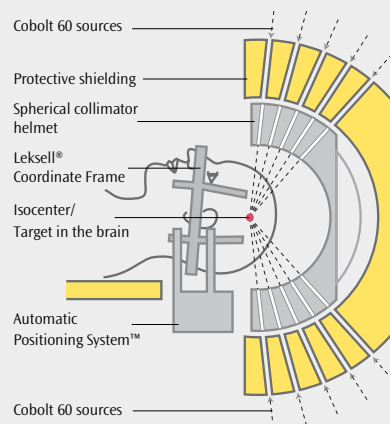

“What does Gamma Knife surgery mean for a neurosurgeon or a radiation oncologist? It simply means that you can get your patients done, and the rest of the day is free for other activities. You can care for other kinds of patients, do other operations, do research.



The efficiency of Gamma Knife surgery is unparalleled. For that reason, I can think of no better tool to fit into my practice. The reason Gamma Knife surgery has remained the gold standard and continues

to grow in use, is because, simply put, it works. As we look ahead, the use of radiosurgery, and Gamma Knife surgery in cancer is just beginning.

Leksell Gamma Knife is the gold standard for the care of brain disorders because of accuracy, efficiency, and the ability to create sophisticated and unparalleled, conformal dose plans. We rely on it to manage the spectrum of brain disorders that we see, with long-term results that support it being the best.”

Douglas Kondziolka, M.D., M.Sc., University of Pittsburgh Medical Center, Center for Image Guided Radiosurgery, Pennsylvania, USA

Functional Mapping

A large number of people suffer from different types of brain disorders. Prior to both surgery and other treatments within the brain, it is critical to document the anatomy of the patient as well as to map functional centers in the brain.

In investigation and treatment of brain disorders, be it tumors, neurodegenerative diseases or functional disorders, it is of the utmost importance to gather as much information as possible about the individual patient's brain. For this, a multitude of tools are available.

Structural information comes from CT and MRI, metabolic information from PET, functional information from fMRI and there are also a number of cognitive tests available. But at most neurology centers, clinicians and neuroscientists do not have a good enough tool to combine information about temporal and spatial localization of relevant functional centers in the brain.

Using magnetoencephalography (MEG), it is possible to determine the function of different parts of the brain for each specific patient in the current stage of his or her development. This

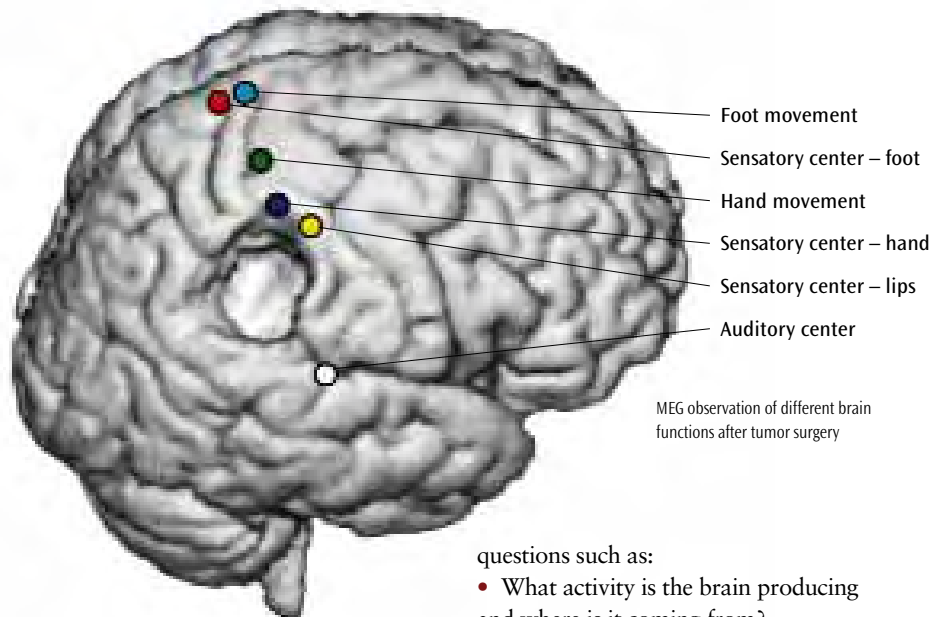

information renders an important piece of the puzzle for diagnosing and treatment planning for patients with certain brain disorders.

MEG measures the magnetic field produced by the brain and non-invasively localizes neural activity in real time. The result is a functional image of brain impulse pathways which answers

questions such as:

- What activity is the brain producing and where is it coming from?
- Which parts of the brain undertake various tasks?
- How does the brain function, both normally and in case of illness?

MEG offers a unique combination of fine-spatial and fine-temporal resolution with millimeter and submillisecond accuracy. With Elekta Neuromag® clinicians and researchers can pinpoint brief

Elekta Neuromag®



Elekta Neuromag® is the world's most advanced magnetoencephalography system, representing a new standard for combined MEG/EEG devices offering the market's densest sensor array, highest amount of neuromagnetic information per sample, highest sampling rate, lowest system noise and longest cryogenic refill interval.

Elekta Neuromag also performs measurements differently from other MEG products. The unique sensor design combined with Elekta's advanced software makes it possible to gain data with unsurpassed details even from the deepest realms of the brain.

The system also has the highest available immunity to magnetic interference, either patient related or environmental. The patient

helmet array provides field distribution sampling at 510 distinct positions, with sensors configured into a total of 306 independent channels.



spontaneous events as well as the sources of evoked responses from brain areas responsible for example somatosensory, auditory, visual, and language processing.

Around the world, researchers are developing clinical MEG routines. The steadily growing list of applications include pre-surgical mapping for neurosurgery, as well as MEG-MRI integration to enhance the accuracy of surgical navigation and planning of open surgery, radiosurgery and radiation therapy. MEG technology can also potentially be used to localize functional targets prior to Gamma Knife® surgery, as well as conventional neurosurgery.



Surgery is a common alternative for those suffering from drug-resistant focal epilepsy. The surgery can be more precise with the use of MEG and the technology has proved especially useful in locating epileptogenic zones in relation to other functionally important regions of the brain.

Elekta's history of instrumentation and software development within MEG spans 20 years and five system generations – from early prototypes to today's multi-channel systems covering the entire head. More than 50 percent of all published articles relating to MEG cite the use of Elekta Neuromag equipment, a convincing indication of Elekta's leadership in MEG technology.

Neurologists in Finland localize LKS foci with MEG

While uncommon, patients with Landau-Kleffner Syndrome (LKS), face permanent disability if they are left untreated. Fortunately, at The Hospital for Children and Adolescents in Helsinki, Finland, the use of Elekta Neuromag® has made treatment a more precise and effective enterprise – ultimately helping children regain the power of speech.

“The origins of epileptic activity in LKS is discovered by mapping brain signal patterns. The typical patterns can first be seen on EEG, which measures electrical signals and is widely available in hospitals,” says Ritva Paetau, M.D., Pediatric Neurologist and LKS expert.

“Standard EEG analysis, however, does not identify where in the brain the disturbance is located. The surgical procedure for LKS is complicated and without the very precise answers that can be gained from MEG, there is a risk of selecting the wrong patients for surgery.”



Ritva Paetau, M.D.,
Pediatric Neurologist
and LKS expert,
Hospital for Children
and Adolescents (HCA),
Helsinki, Finland

“The challenge is to find the ‘pacemaker area’ of rapidly spreading epileptic spikes – and then destroy its ability to generate large enough signals to trigger propagated activity to other brain areas,” Ritva says. “In other words, to cut the horizontal connections between local pyramidal cells to the ‘critical mass of the spike’. The more pyramidal cells, the larger spike amplitude and the more likely the spike will spread through synaptic connections to other brain regions. Because this pacemaker area can be identified using Elekta Neuromag on top of standard EEG, we can focus on surgery in this area, thereby halting the spread of the spikes with a minimal lesion”.



Stereotactic Neurosurgery

The driving force in the treatment of brain disorders is to achieve the highest possible level of precision, in order to match the very narrow margins. Elekta's advanced system for stereotactic neurosurgery provides neurosurgeons with the highest level of clinical accuracy.

Elekta's founder, the late professor of neurosurgery Lars Leksell, developed a new method for brain surgery that was less traumatic and entailed less risk to the patient. The result was the so-called stereotactic frame providing a three-dimensional reference system which allows the surgeon to very accurately localize and treat the pathological area with great precision.

The simple, effective design of the frame provides the versatility for a wide range of applications for diagnostic, therapeutic, functional and microsurgical procedures. The unsurpassed accuracy



is obtained through the solid fixation of the frame to the skull. In contrast to conventional cranial surgery, minimally invasive surgery only requires a small burr hole, making the procedure less traumatic and significantly increasing the speed of patient recovery.

The range of surgical possibilities available through the applications of stereotactic techniques is increasing all the time. This strengthens the chances of finding the optimal treatment modality for each individual patient, thus increasing the chance of success and the cost efficiency of the approach.

In day-to-day use the frame based stereotactic system has been shown to provide significant advantages over other fixation solutions. The Elekta solution has the largest stereotaxy user group in the world and it is being used at over 1,100 clinical centers and academic institutions worldwide.

The principles of Stereotaxy

The spelling of the word stereotactic is derived from the Greek word stereo for three-dimensional and the Latin word tactus meaning to touch. Stereotactic surgery involves more than merely displaying the brain in three dimensions. It also makes it possible to touch structures deep within the brain, without visual control.

The principles of stereotactic surgery are based on the use of a rectilinear (Cartesian) coordinate system.

The localization procedure has the purpose of assigning a numerical value to each one of the three axes of the coordinate system (X, Y, Z). The point of intersection of all three axes thereby defines the target point. By applying the coordinate frame to the patient, the surgical target is encompassed by a well-defined three-dimensional space, i.e. the stereotactic space.

By attaching a semicircular arc to the frame, its center is brought to exactly coincide with the X, Y and Z points described above. Since the probe to be used has the same length as the arc radius, its tip will always be on the target when it is inserted to its full length.

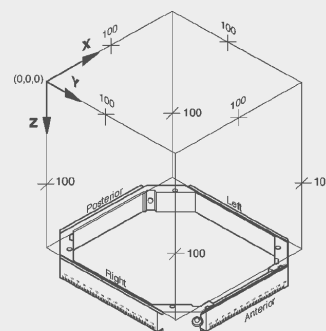

Leksell Stereotactic System®

The core system within Elekta's solutions for stereotactic neurosurgery is Leksell Stereotactic System®, a three-dimensional reference system which allows the surgeon to accurately localize and treat brain disorders with high accuracy. The system is used for diagnostic – such as biopsies – as well as therapeutic procedures for treatment of functional disorders and of deep-seated targets, hard to reach with conventional surgery. Leksell Stereotactic System is also a vital component of

Leksell Gamma Knife® where it enables a highly precise, non-invasive, radiosurgical treatment.

Together with two other major components, Leksell SurgiPlan® for pre-operative planning and Leksell® Neuro Generator for lesioning and stimulation, Leksell Stereotactic System constitutes one integrated system. Another fully integrated component is Elekta MicroDrive™, designed to find the optimal electrode position for treatment of certain functional disorders.





“From a practical point of view, you can’t get more accuracy than in frame-based Stereotaxy. When using the frame you superimpose the Cartesian coordinate system on the brain and can be in control. When using a ‘frameless’ system you’re not in direct control yourself – that’s the main difference!”

Dr P. R. Schuurman, M.D., Ph.D.
Academic Medical Center, University of Amsterdam, the Netherlands

Board of Directors' report*

The Board of Directors and the President of Elekta AB (corp. reg. no. 556170-4015) hereby submit the annual report and consolidated accounts for the fiscal year from May 1, 2004 to April 30, 2005.

Operations

Elekta is an international medical-technology group, developing advanced clinical solutions and information systems for radiation therapy for cancer, as well as for non-invasive and minimally invasive treatment of brain disorders.

Elekta provides world-leading, innovative clinical solutions in:

- Precision Radiation Therapy
- Image Guided Radiation Therapy
- Stereotactic Radiation Therapy
- Gamma Knife® surgery
- Stereotactic Neurosurgery
- Functional Mapping

Elekta also offers advanced software for workflow management, treatment planning, decision support and information processing. With the acquisition of IMPAC Medical Systems, Inc. in April 2005, Elekta became the world's largest supplier of software for cancer treatment.

Elekta also offers extensive programs for upgrades and service of both hardware and software intended to safeguard the value of the customer's investment during the product's entire lifecycle.

Market

Due mainly to a longer life expectancy and better diagnostics, the number of newly diagnosed cases of cancer is steadily increasing.

Radiation therapy is an important weapon in the fight against cancer. Approximately 50 percent of patients diagnosed with cancer require treatment with radiation therapy during some part

of the course of the disease. New, advanced methods such as image guidance and stereotactic applications are expected to increase the use of radiation therapy in the future. This development is accelerated by the fact that radiation therapy is cost-effective compared with other cancer treatment methods while also being more gentle to the patient.

Elekta has unique experience of more than 30 years in image guidance and stereotactical applications in radiation treatment. On the basis of this experience, Elekta now leads the development of new advanced methods for radiation therapy of cancer.

Leksell Gamma Knife® is the predominant and most advanced method for stereotactic radiosurgery in the brain, and development toward expanded areas of application continues.

The total market for Elekta's products and solutions is expected to grow by 5-10 percent annually, and demand for Elekta's clinical solutions remains strong. However, the high value of individual orders and order coordination within the framework of health care investment programs often lead to significant quarterly variations in business volume.

Competition

The global market for radiation therapy is dominated by three companies: Elekta, Varian Medical Systems and Siemens

Medical Solutions. Elekta continues to increase its market share and is currently the world's second largest supplier. In all markets, Elekta's share of units sold is larger than its share of the installed base.

In the market for Gamma Knife surgery, Elekta has no direct competitors, although Leksell Gamma Knife in certain areas competes with other less accurate and less clinically proven treatment methods.

In the market for magnetic encephalography systems (MEG), Elekta Neuromag® is the market leader. The market potential is difficult to assess, since this technology is in a transition stage from having been primarily a research tool to becoming a routinely used clinical method.

The market for administrative software and information processing systems for cancer care is dominated by IMPAC, with Varian Medical Systems as the largest competitor. The US market for IT systems for radiation therapy is relatively well penetrated, while the potential for market growth in the rest of the world is considerable.

Order bookings and order backlog

Order bookings rose by 9 percent to SEK 3,558 M (3,262). IMPAC, which was included during April, contributed with SEK 40 M. Order bookings for oncology products rose by 12 percent to

Order bookings

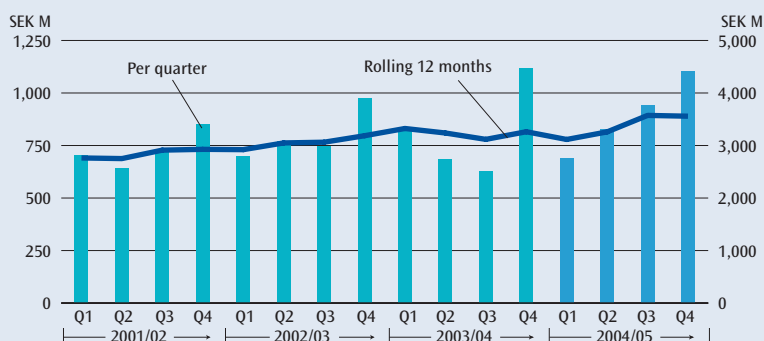

* In addition to these pages, the Board of Directors' report includes the comments on financial results and position provided in conjunction with the income statement, balance sheet, changes in shareholders' equity and cash flow statement on pages 38 to 45.

<i>Order bookings</i>			
SEK M	2004/05	2003/04	Chg, %
Europe, Middle East, Africa North and South America	1,537	1,476	4
Japan	262	229	14
Asia excl. Japan	388	492	-21
Group	3,558	3,262	9
of which:			
Oncology	2,600	2,331	12
Neurosurgery	958	931	3

SEK 2,600 M (2,331). Order bookings for neurosurgery products were up 3 percent, amounting to SEK 958 M (931). Based on unchanged exchange rates, the Group's order bookings rose by 12 percent, with oncology rising by 13 percent and neurosurgery by 8 percent.

The order backlog amounted on April 30, 2005 to SEK 3,493 M (2,728). IMPAC is contributing with SEK 432 M. The order backlog is at a record high level, even when adjusted for IMPAC's contribution.

Market comments

Elekta markets clinical solutions, IT systems and services all over the world. Marketing and sales are conducted via a sales and service organization that is divided into four regions.

Europe, Middle East and Africa

Order bookings in region Europe, including the Middle East and Africa, rose by 4 percent to SEK 1,537 M (1,476). Based on unchanged exchange rates, total order bookings for the region rose 4 percent, and for oncology products, by 13 percent.

Elekta's position in the European market is strong. The market for radiation therapy is driven primarily by the lack of care capacity and therapeutic equipment. In many European countries, the number of linear accelerators per capita is less than half that of the US.

Extensive investment programs are ongoing in several European countries,

including France, the Netherlands and the UK, aimed at increasing capacity for radiation therapy of cancer. The acquisition of IMPAC is expected to result in a strengthened market position, with regard to treatment equipment as well as software systems.

North and South America

Order bookings in North and South America increased by 29 percent to SEK 1,371 M (1,065), including SEK 34 M attributable to IMPAC. Based on unchanged exchange rates, order bookings for the region rose by 36 percent. Order bookings for oncology rose by 30 percent, while order bookings for neurosurgery were up 47 percent, based on unchanged exchange rates.

An order for ten linear accelerators to Venezuela, valued at over SEK 100 M, was booked during the fourth quarter, of which two systems were delivered in April 2005.

The growth in the US market, which was previously driven by the transition to intensity modulated radiation therapy (IMRT), has now slowed down. Interest in the next technology shift – image guided radiation therapy (IGRT) – is substantial, primarily from university hospitals. In a near future, IGRT is also expected to be ready for a broader market. This is likely to strengthen market growth, primarily through higher price per sold unit.

In the American market, efficiency in the patient flow and the management of the clinic's information flows are often decisive sales arguments. Accordingly, software systems such as those offered by IMPAC, which span the entire clinical treatment process and administratively manage resource utilization, are discussed in most sales processes.

Japan

Order bookings in Japan rose by 14 percent to SEK 262 M (229). Based on unchanged exchange rates, order

bookings increased by 19 percent.

Elekta holds a strong position in the Japanese market, particularly within neurosurgery. A relatively high penetration of Leksell Gamma Knife in Japan entails a good potential for upgrades and after-market sales. The latest generation of Leksell Gamma Knife, the 4C version, is expected to be approved by the Japanese authorities during the autumn of 2005, which will expand upgrades and after-sales opportunities in the region.

Japan is a pioneer country in magnetoencephalography (MEG). Elekta Neuromag® has a relatively high penetration in Japan and interest there continues to be strong.

Asia

Order bookings in Asia, excluding Japan, declined by 21 percent to SEK 388 M (492). Based on unchanged exchange rates, total order bookings for the region declined 20 percent, and for oncology products, by 15 percent.

Elekta holds a strong market position for advanced and premium-priced solutions in the region. The need for equipment for radiation therapy for tumor diseases is very high in most Asian countries. Competition on the Asian markets for linear accelerators is becoming increasingly intense, primarily from suppliers of equipment with simpler designs and lower prices.

The need for equipment for radiosurgery is great in the region, and several countries in the region have shown a clear interest in investing in Leksell Gamma Knife.

After-market

Order bookings for Elekta's after-market products, including technical service, amounted to SEK 1,092 M (1,087). During the period, fewer orders were signed for multi-year service contracts than in the preceding year.

The installations of Elekta IntelliMax™, Elekta's unique Intelligent Device Management (IDM) system, are continuing according to plan. The system permits ongoing Internet-based supervision and follow-up of Elekta's digital linear accelerators and creates a potential for ongoing enhancement of efficiency and quality in Elekta's international service operations.

Net sales

SEK M	2004/05	2003/04	Chg, %
Europe, Middle East, Africa North and South America	1,328	1,319	1
Japan	326	303	8
Asia excl. Japan	441	410	8
Group	3,152	2,900	9
of which:			
Oncology	2,175	1,876	16
Neurosurgery	977	1,024	-5

Net sales

Consolidated net sales rose by 9 percent to SEK 3,152 M (2,900), including SEK 47 M attributable to IMPAC. Based on unchanged exchange rates, net sales rose by 13 percent, in line with Elekta's financial objective of 10-15 percent.

Net sales for oncology products increased by 16 percent to SEK 2,175 M (1,876). For neurosurgery products, net sales declined 5 percent to SEK 977 M (1,024).

Earnings

Operating profit rose by 14 percent to SEK 349 M (306), primarily from increased sales volume. Compared with the corresponding period during the preceding year, exchange rate changes had a negative effect of about SEK 61 M on operating profit. The operating margin amounted to 11 percent (11).

Net financial items amounted to income of SEK 14 M (19), of which net interest income of SEK 7 M (11) and shares in the earnings of associated

companies of SEK 7 M (8).

Profit after net financial items amounted to SEK 363 M (325). The tax expense was SEK 122 M, or 34 percent. Profit after taxes amounted to SEK 241 M (248).

Earnings per share rose to SEK 7.69 (7.63) before dilution and to 7.67 (7.63) after dilution.

Return on shareholders' equity amounted to 16 percent (17), while return on capital employed amounted to 20 percent (20).

Acquisition of IMPAC Medical Systems, Inc.

On April 4, 2005, the stockholders of IMPAC Medical Systems, Inc. approved the agreement with Elekta to merge IMPAC with a subsidiary of Elekta. Following the merger that took place the same day, IMPAC has become a wholly owned subsidiary of Elekta. Elekta paid USD 24.00 in cash for each share of IMPAC common stock outstanding. Acquisition value including direct acquisition costs amounted to USD 257 M (SEK 1,812 M). At the time of the acquisition, IMPAC had liquid funds in an amount of USD 61 M (SEK 428 M).

The initial accounting of the fair values to be assigned to the acquiree's identifiable assets and liabilities has only been provisionally established, due to the short time between acquisition and the year-end closing of Elekta's accounts. The initial accounting will be completed during fiscal 2005/06. Intangible fixed assets and goodwill have been valued at USD 222 M. Amortization period for intangible fixed asset varies between 1 and 20 years.

Elekta has merged the sales forces of both companies and will continue to coordinate or integrate operations, as and when it is deemed to benefit customers or the efficiency of the Group.

Elekta has already started to win orders, for both hardware and software, in the US and internationally, that

management believes are direct results of the business combination.

Investments and depreciation /amortization

The acquisition of IMPAC resulted in an increase in intangible and tangible fixed assets of SEK 1,597 M. Other investments in intangible and tangible fixed assets amounted to SEK 85 M (99). Depreciation and amortization of intangible and tangible fixed assets amounted to SEK 106 M (88).

Liquidity and financial position

Cash flow from operating activities amounted to SEK 408 M (448).

Cash flow after investments was negative SEK 1,042 M (pos: 363), of which a negative SEK 1,384 M was attributable to the acquisition of IMPAC.

On April 30, 2005, liquid funds amounted to SEK 744 M (1,151). SEK 52 M of bank balances were pledged, primarily for commercial guarantees.

Interest-bearing liabilities amounted to SEK 833 M (231). The acquisition of IMPAC was financed partly by raising loans in USD.

Sensitivity analysis

Elekta's gross margin, meaning sales minus costs for sold products, can vary considerably from period to period depending on project deliveries, product and geographic mix and currency movements.

The margin on products that Elekta merely distributes is lower than the margin on proprietary products. The margin on different proprietary products also varies. During the year, Elekta had a gross margin of 38 percent (39).

Elekta's net sales for the coming 12-month period are mainly determined by the order backlog. Delays of deliveries are relatively common but can be offset during the year by additional orders with shorter delivery times.

The majority of Elekta's costs are in SEK and GBP, while sales are mainly in USD, EUR and JPY. A general change of 1 percent in the exchange rate for SEK against other currencies affects the Group's profit by about SEK 9 M, given the current structure and business focus. Elekta hedges a portion of the net exposure in each currency over a rolling 24-month period. The scope of this hedging is determined by the company's assessment of currency risks.

Research and development

Elekta conducts intensive R&D work aimed at strengthening and enhancing the company's position as a leading player in its markets and product areas. During the year, SEK 230 M, corresponding to 7 percent of net sales, included investments in the following areas:

- Within neurosurgery, R&D focused on further enhancements of minimally invasive and cost-effective technologies for diagnosis and treatment of brain disorders. Intensive efforts are being made to transfer Elekta's many years of experience in stereotaxy and radiosurgery to radiation therapy for cancer in the entire body and thus achieving significant clinical advances through greater precision in radiation treatment.
- In radiation therapy, products and methods are being refined for greater precision and improved clinical results, among other methods through image guided radiation therapy (IGRT). Elekta's R&D undertakings involve both new software applications and new equipment. The company has achieved a world-leading position within IGRT in which high resolution 3D imaging is integrated with treatment equipment.
- Within the framework of R&D operations, Elekta also conducts clinical research in close cooperation with leading neurosurgery and oncology clinics throughout the world.

- Within IMPAC the R&D investments are on a higher level, compared with the total Group, which is natural in a software business. IMPAC's R&D organization is focusing its efforts on continued development of world leading software systems for the whole spectrum of cancer care, most of which is based on the new IQ platform.

Employees

The average number of employees was 1,249 (1,136). The number of employees on April 30, 2005 totaled 1,671 (1,170), of which 421 in IMPAC.

Value-added per employee amounted to SEK 928,000 (902,000).

IT

Use of IT support is being increased throughout the organization. Elekta has continued its investments in efficient communications and systems solutions to ensure the information requirements in the business. The IT infrastructure is being continuously expanded to support business processes and to strengthen productivity and competitiveness.

During the 2004/05 fiscal year, Elekta decided to implement a new business system for the entire Group. The total costs for the global ERP (Enterprise Resource Planning) system are estimated at SEK 65-80 M. The ERP project is expected to result in significant cost savings and efficiency gains.

Quality

Elekta works determinedly to improve and assure quality in all processes within the Group. Quality work also ensures that all government requirements are fulfilled. All Elekta's development and production units are certified in accordance with the relevant ISO 9000 and EN 46000 where appropriate. Elekta conducts regular audits to ensure that the Group complies with the requirements that various supervisory authorities have established for medical technology companies.

Parent Company

The operations of the Parent Company include Group management and joint Group functions and financial management. The Parent Company's profit after net financial items amounted to SEK 39 M (22). The average number of employees was 16 (17).

New financial objectives for the Elekta Group

Elekta conducts its operations with financial objectives to achieve sustainable profitable growth. The objectives form the base for the Group's operational planning. The Board has revised Elekta's financial objectives for fiscal years 2005/06–2007/08:

- Elekta has an unchanged annual sales growth objective of 10-15 percent in local currency.
- The Group has the objective to increase its profitability. The operating margin objective has been increased to reach 14-16 percent not later than for fiscal year 2007/08.
- Return on the Group's capital employed shall exceed 20 percent.
- The Group's objective for financial stability has been revised. The equity/assets ratio has been replaced by a net debt/equity ratio objective that shall not exceed 0.25.

Future prospects for fiscal year 2005/06

Demand remains favorable for Elekta's clinical solutions and IT-systems. The order backlog is at a record high level.

For full-year 2005/06, Elekta expects a growth in sales in line with the Group's objective of 10-15 percent in local currency, on a comparative basis.

Operating margin for full-year 2005/06 is expected to be in the range of 11-13 percent.

Dividend policy and proposal to repurchase shares

Elekta's goal is to provide shareholders with a favorable return and value growth. According to the company's dividend policy, the goal is to distribute 20 percent or more of net profit to the shareholders in the form of dividends, share repurchases or comparable measures. Decisions regarding dividend payments are based on Elekta's financial position, the expected profitability trend, growth potential and investment needs.

In accordance with the company's dividend policy, the Board has decided to propose a dividend of SEK 1.60 per share to the Annual General Meeting on September 21, 2005.

Against the background of the company's strong financial position, stable cash flow and current capital structure, the Board also has decided to propose a payout of an extra dividend of SEK 5.00 per share.

Accordingly, the Board will propose to the Annual General Meeting a total dividend for fiscal year 2004/05 in an amount of SEK 6.60.

The Board also decided to propose to the Annual General Meeting on September 21, 2005 a new authorization for the Board to repurchase a maximum of 10 percent of the number of shares outstanding in Elekta AB. The decision on repurchases will be made ongoing during the year based on the share price performance, Elekta's financial position, profitability trend and investment needs. The Board intends to propose to the Annual General Meeting that any shares repurchased as part of the company's dividend policy will be cancelled.

As of August 18, 2005, Elekta held 224,900 of its own B shares, repurchased as part of the company's dividend policy. The Board will propose to the Annual General Meeting that the repurchased shares be cancelled.

Transition to IFRS

Effective May 1, 2005, Elekta will prepare its consolidated accounts in accordance with the International Financial Reporting Standards (IFRS, formerly IAS) approved by the EU. The 2004/05 Annual Report will be the last prepared in accordance with the recommendations and statements of the Swedish Financial Accounting Standards Council.

The interim report for the period May-July 2005 will be the first report presented by Elekta in accordance with IFRS. The comparable figures for the 2004/05 fiscal year will be restated in accordance with IFRS. Financial information related to fiscal years prior to 2004/05 will not be restated.

The rules for adoption of IFRS are provided in IFRS 1 (First-time Adoption of International Financial Reporting Standards). The net effect of the change in accounting principles is reported directly against shareholders' equity. The significant changes in accounting principles as a result of applying IFRS, as well as the preliminarily calculated effects on the balance sheet on April 30, 2005, are presented below.

Business combinations and goodwill

In accordance with IFRS 3 (Business Combinations) goodwill is no longer amortized. Instead, an impairment test must be carried out each year to determine whether there is any write-down requirement regarding goodwill. Based on IFRS 1, Elekta has chosen not to recalculate acquisitions of subsidiaries and associated companies carried out prior to May 1, 2000. The net value of goodwill existing on May 1, 2004, will be considered as the new acquisition value. Acquisitions during fiscal 2004/05 have been reported in accordance with IFRS 3. Amortization applied during 2004/05 amounting to SEK 25 M will be reversed. In certain companies, goodwill is tax deductible, as a result of which deferred tax is affected in the amount of SEK 6 M.

Proposal for share split

Against the background of the Elekta share's strong price performance, the Board has decided to propose to the Annual General Meeting a 3-for-1 share split, in which each old A and B share respec-

Financial instruments and hedge accounting

IAS 39 (Financial Instruments: Recognition and Measurement) is applied from May 1, 2005. Based on IFRS 1, Elekta has chosen not to restate the comparable figures for 2004/05 regarding financial instruments in accordance with IAS 39. The difference between the reported values in accordance with IAS 39 and the previously applied accounting principles will be reported in the balance sheet at May 1, 2005 directly against shareholders' equity in accordance with the transition rules in IFRS 1. An amount of SEK 15 M is reported for financial instruments, SEK 4 M in deferred taxes related to these, and shareholders' equity is increased by SEK 11 M. Financial liabilities shall be measured at amortized cost, with the effect that prepaid expenses and interest-bearing liabilities both decline by SEK 2 M.

Share-based payments

Elekta's outstanding 2004/2008 options program is covered by IFRS 2 (Share-based payments), which means that a calculated cost based on the fair value of the instruments on the issue date shall be reported in the income statements distributed over the earnings period. The calculated cost of the 2004/05 fiscal year amounts to SEK 10 M and deferred tax related to the options program to SEK 3 M.

Minority interests

According to IAS 27 (Consolidated and Separate Financial Statements), minority shares of shareholders' equity must be reported as a separate component in shareholders' equity on the balance sheet and not as a separate item among liabilities. In the income statement, minority shares of earnings may no longer be eliminated, but must be included in reported income for the period. It must be specified in the income statement what proportion of the profit for the year is attributable to the owners of the parent company and to the minority owners of subsidiaries.

tively, is replaced by three new shares.

Responsible business and operations

For a global company active in the health care sector, it is very important that all operations are conducted in a

Summary of the preliminary effects of the transition to IFRS

Income Statement 2004/05, SEK M	Current principles	IFRS adjustments	IFRS principles
Net sales	3,152	—	3,152
Cost of products sold	-1,948	14	-1,934
Gross profit	1,204	14	1,218
Selling expenses	-408	6	-402
Administrative expenses	-285	-4	-289
R&D expenses	-235	-1	-236
Currency exchange differences in operations	73	—	73
Operating profit	349	15	364
Income from participations in associated companies	7	—	7
Interest income	22	—	22
Interest costs and similar profit/loss items	-15	—	-15
Financial currency exchange differences	0	—	0
Profit after financial items	363	15	378
Taxes	-122	-3	-125
Profit for the year	241	12	253
Balance sheet April 30, 2005, SEK M			
Intangible fixed assets	1,895	25	1,920
Tangible fixed assets	189	—	189
Financial fixed assets	22	—	22
Inventories	362	—	362
Receivables	1,266	—	1,266
Liquid funds	744	—	744
Total assets	4,478	25	4,503
Shareholders' equity	1,674	20	1,694
Provisions	281	5	286
Interest-bearing liabilities	833	—	833
Interest-free liabilities	1,690	—	1,690
Total shareholders' equity, provisions and liabilities	4,478	25	4,503
Balance sheet May 1, 2005, SEK M			
Intangible fixed assets	1,895	25	1,920
Tangible fixed assets	189	—	189
Financial fixed assets	22	—	22
Inventories	362	—	362
Receivables	1,266	13	1,279
Liquid funds	744	—	744
Total assets	4,478	38	4,516
Shareholders' equity	1,674	31	1,705
Provisions	281	9	290
Interest-bearing liabilities	833	-2	831
Interest-free liabilities	1,690	—	1,690
Total shareholders' equity, provisions and liabilities	4,478	38	4,516

No changes in opening balance May 1, 2004.

manner that is socially, environmentally and financially responsible. This is not least a prerequisite for attracting customers, employees and investors.

All managers and employees in Elekta, as well as the Group's partners in the

form of suppliers, consultants, agents and distributors, are expected to adhere to good ethics both professionally and personally in their work for Elekta.

The "Elekta Code of Conduct" describes the most important ethical

principles that Elekta expects all employees and partners to follow and maintain in their work. The code is based on Elekta's vision, mission and values and constitutes an essential foundation in the work to create a strong and well-respected brand that supports a long-term and sustainable market presence and growth.

The "Elekta Code of Conduct" is available at www.elekta.com.

Environmental responsibility

Elekta's business shall comply with applicable environmental laws and regulations and fulfill the terms of Elekta Environmental Policy, which specifies the requirements for Elekta's operations to, wherever possible, minimize adverse effects on the environment.

The EU environmental agenda is set out in its "Sixth Community Environment Action Programme". Similar legislation is also in preparation in other parts of the world. Elekta participates in government consultations and committee work within the national and international bodies that formulate the actual standards.

As of August 2005, all manufacturers of electrical and electronic equipment within the EU will be obligated to take back used equipment for environmentally compatible recycling. Elekta is well prepared for meeting these requirements.

As of July 1, 2006, certain poisonous substances are prohibited and the use of others limited in most electrical and electronic products. Although this directive does not include medical equipment, Elekta will gradually make a transition to electronics that meet these requirements as far as possible.

Through the Kyoto Protocol, the EU has committed to reducing carbon dioxide emissions by 8 percent before 2010. The CO₂ emissions generated by Elekta's operations derive primarily from travel. External observers consider Elekta as a company with low environmental impact, and the company's climate work is given excellent marks.

Corporate governance

Following Swedish regulations, recommendations and standard practice, Elekta strives for a corporate governance regime that is fair, transparent and manageable.

Annual General Meeting

The shareholders' right of decision in Elekta AB's affairs is exercised at the Annual General Meeting (AGM). The AGM is held in Stockholm, Sweden in September. Notification of the AGM is provided not earlier than six and not later than four weeks in advance. All registered shareholders receive an invitation to the AGM together with a copy of the Annual Report. All relevant documentation for the AGM is made available at the company's head office and on Elekta's website (www.elekta.com). Shareholders may register to participate by post, fax or e-mail. The language for AGM, as well as all documentation, is Swedish.

To be able to participate in decisions, shareholders must be present at the AGM personally or via a representative.

Matters considered at the AGM include dividend, adoption of the Annual Report, election of members of the Board of Directors as well as auditors if applicable, remuneration to the Board of Directors and auditors as well as other important issues.

Series A shares entitle the holder to ten votes, while series B shares carry one vote. Decisions are normally taken by simple majority.

Work of the Board of Directors

Elekta's Board of Directors is elected by the Annual General Meeting. The Board of Directors establishes Elekta's strategy and goals, ensures an effective evaluation of operations and controls the company's development and financial position. The Board of Directors consists of six persons, who are presented on page 35.

Presently, five of the six Board members are independent with respect

to company management and major shareholders.

At the statutory meeting of the Board of Directors on September 21, 2004, Akbar Seddigh was re-elected as Chairman. During the 2004/05 fiscal year, the Board held seven recorded meetings with Elekta's General Counsel acting as secretary.

Working instructions

Within the Board of Directors, there is no special distribution of responsibility among Board members.

Apart from the responsibilities assigned by the Swedish Companies Act, the work of the Board of Directors is regulated by its working instructions, which stipulates that the Board should:

- Hold at least five ordinary meetings in addition to the statutory meeting
- Establish finance and currency policies
- Approve budgets and similar long-term plans including investment budgets
- Consider matters regarding investments and similar measures in amounts over SEK 4 M if such matters are beyond the scope of approved investment budgets
- Decide on acquisitions of fixed property, shares or the acquisition of operations in another company
- Decide on the establishment and capitalization of subsidiaries
- Establish the terms of employment for the CEO
- Approve the annual accounts, Board of Directors' report and interim reports

At each ordinary Board meeting, the following items should be considered:

- A report on the Group's operations including financial management
- A report on extraordinary measures or events that were implemented or occurred between Board meetings
- Development of major projects and anticipated business events
- A report on existing or potential legal disputes that may have a significant impact on the Group's business

Significant decisions during the year

In addition to decisions on plans and strategies, continuous follow-up of business operations and approval of interim and year-end reports, the Board of Directors during the 2004/05 fiscal year decided on matters including:

- Acquisition of IMPAC Medical Systems, Inc.
- Strategy for production, purchasing and logistics
- Implementation of a new Group-wide ERP system
- Issues regarding organization and management succession planning
- Policies for Corporate Social Responsibility and financial information
- Strategy for expansion into new markets
- Capital structure and repurchase of shares
- Strategy for growth in the after-market

As part of its work, the Board of Directors visits Elekta's major units around the world. During the year, the Board met with management for US operations in conjunction with one of the major medical conferences in the the US and held a Board meeting at Elekta's facility in Crawley, UK.

Representatives from Group management and other management personnel participated regularly in Board meetings during the year to report on matters within their respective areas.

Each new Board member of Elekta receives a thorough introduction to the company and as a rule visits at least two of the company's major units.

Elekta does not extend share- or share price-related incentives programs to Board members who are not employees of the company.

Executive Compensation Committee

Elekta's Executive Compensation Committee (ECC) consisted during the year of Board Chairman Akbar Seddigh, Board member Magnus Schmidt and President Laurent Leksell. Group VP Human Resources Karin Isberg served as secretary. The purpose of the Committee is to provide clarity in the decision process for all issues related to compensation of

Board of Directors



AKBAR SEDDIGH

Chairman, born: 1943

Member of the Board since 1998
 Holdings: 1,100 B shares
 Graduate Chemist, Marketing Specialist
Other Board memberships:
 Chairman of the Board: Artimplant AB, Fomo Services AB, Ortivus AB
 Board member: Affärstrategerna AB, Biolight International AB



HANS BARELLA

born: 1943

Member of the Board since 2003
 Holdings: —
 Former President and CEO of Philips Medical Systems
Other Board memberships:
 Board member: Senator Group Consultancy and Investment B.V.



TOMMY H KARLSSON

born: 1946

Member of the Board since 2001
 Holdings: 550 B shares
 International Management Consultant, MSc and B.A.
Other Board memberships:
 Chairman of the Board: Global Gardening Products S.A., MSC S.A.
 Board member: Intenia AB, Knurr AG



LAURENT LEKSELL

born: 1952

Member of the Board since 1974
 Holdings: 1,187,500 A shares, 1,256,893 B shares (incl. via family and companies)
 Previously President of Elekta AB
 PhD Economics
Other Board memberships:
 Board member: Ortivus AB



CARL G. PALMSTIERNA

born: 1953

Member of the Board since 1993
 Holdings: 46,677 B shares
 Managing Partner ABG Sundal & Collier AB, MBA
Other Board memberships:
 Board member: CNS Systems AB, Preferred Global Health Inc., QBrick AB



MAGNUS SCHMIDT

born: 1940

Member of the Board since 1998
 Holdings: 3,000 B shares
 International Consultant, MBA
Other Board memberships:
 Chairman of the Board: Einar Mattsson AB, Fastighets AB Stadshus
 Board member: Benchmark Oil & Gas AB, Upplands Motor Holding AB, Sydkraft Energi Trading AB

executive staff within Elekta as well as other incentive plans throughout the Elekta organization.

The objective of the Committee is to achieve maximum shareholder and customer value through ensuring fairness and internal equality of the structure, scope and level of executive compensation in Elekta while maintaining market competitiveness.

ECC provides the Board with recommendations regarding principles for formulating the Group's compensation system and remuneration to senior executives and senior managers. The recommendations cover formulation of the bonus system, distribution between

Attendance and remuneration for the Board of Directors in Elekta AB 2004/05

SEK 000s	Name	Independent ¹	Regular remuneration	Committee remuneration ²	Attendance, %
<i>Chairman:</i>	Akbar Seddigh	yes	440	60	100
<i>Members:</i>	Hans Barella	yes	220	—	100
	Tommy H Karlsson	yes	220	—	100
	Laurent Leksell	no	— ³	— ³	100
	Carl G. Palmstierna	yes	220	—	100
	Magnus Schmidt	yes	220	30 ⁴	100
Total			1,320	90	

1. Independent in relation to company and management as well as to major shareholders
2. Remuneration to chairman and member in Elekta's Executive Compensation Committee
3. No remuneration is paid to members of the Boards that are employed by the Company
4. Extra remuneration for committee work

fixed and variable remuneration as well as the level of salary increases. The ECC also proposes criteria for assessing performance of senior executives and senior

managers, which are discussed and decided by the Board. The entire Board, excluding the President, decides on remuneration to the President.

Elekta's organization

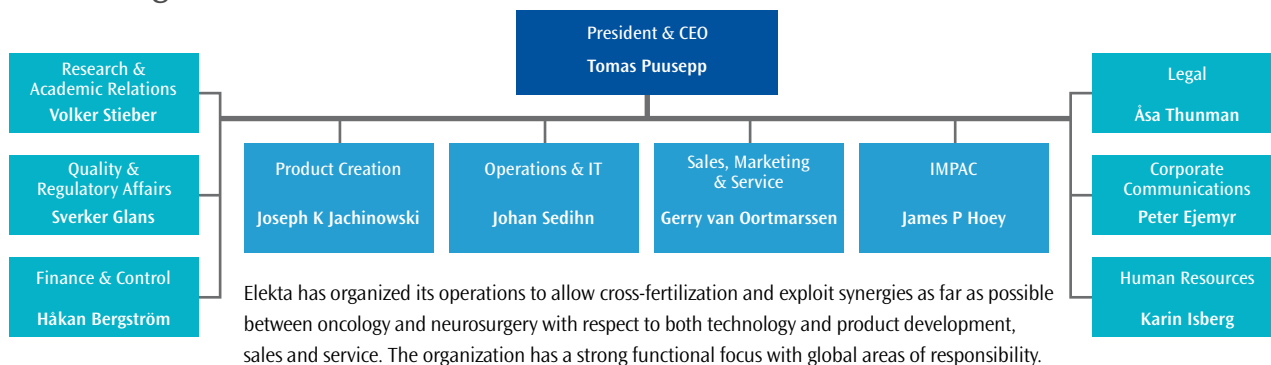

President

On May 1, 2005, Tomas Puusepp was appointed President and CEO of Elekta, succeeding Laurent Leksell, who had been the company's President since its founding.



President & CEO

TOMAS PUUSEPP
born: 1955
Employed since 1988
Shareholding: 53,000 B shares, 23,184 employee share options

During Laurent Leksell's more than 30 years as President, Elekta developed from a small, privately held research-focused company into a global, stock market listed medical technology Group with nearly 1,700 employees.

Tomas Puusepp, born 1955, has a total of 22 years of experience in the international medical technology market. Following studies in engineering and physics and management training at IMD in Lausanne, Switzerland, Tomas Puusepp held various positions at the Research Institute for Atomic Physics, Scanditronix and Ericsson before being employed by Elekta in 1988. Since then, he has held various management positions within the company, including head of Elekta's neurosurgery operations and as President of Elekta's subsidiary in North America. In recent years, Tomas Puusepp has had the global responsibility for Elekta's sales, marketing and service operations.

Tomas Puusepp has no significant assignments outside the company and also has no shareholdings or ownership interests in companies with significant business relations with Elekta.

Nomination Committee

At Elekta's Annual General Meeting on September 21, 2004, it was decided that the nomination process for the 2005 Annual General Meeting should take place through the Chairman of the Board prior to the end of the fiscal year. He should contact at least five of the largest shareholders, who together would prepare a proposal of Board of Directors to be presented to the Annual General Meeting for decision. The Nomination Committee was assigned with appointing a Chairman among its members and announcing the names of the members as soon as they were appointed.

On April 7, 2005, a statutory meeting was held by Elekta's Nomination Committee, which consisted of:

- Robur Funds, Marianne Nilsson
- Egerton Capital Ltd., Charles Evans-Lombe
- SHB/SPP Funds, Torsten Johansson
- Skandia Liv, Caroline af Ugglas
- SEB Funds, Björn Lind
- Laurent Leksell (representing own and family shareholdings)
- Akbar Seddigh, Chairman of Elekta AB

As of March 31, 2005, these shareholders collectively represented 40 percent of the votes in Elekta AB.

The Nomination Committee appointed Laurent Leksell as Committee Chairman.

The Committee has had the assignment to prepare a proposal of Board of Directors to be presented to the Annual General Meeting for decision and to prepare other issues before the Meeting.

Prior to the nomination process, an evaluation was conducted under the Chairman's leadership of the performance of all members of the Board of Directors. This then provided a foundation for the Nomination Committee's discussions.

No compensation was paid to the members of the Nomination Committee.

Auditing issues

In Elekta, all Board members have the commitment and competence to address auditing issues and the full Board deals with accounting and auditing issues at its regular meetings. Accordingly, Elekta's Board of Directors has not appointed a separate Audit Committee. At least at one meeting per fiscal year, the company's external auditors present their observations from the audit, report their views on management and control systems and discuss and report on the



Auditor

LARS SVANTEMARK
born: 1949
Authorized Public Accountant, Deloitte & Touche AB
Senior auditor since 2000

Executive Committee



GERRY VAN OORTMARSEN
born: 1943

Sales, Marketing & Service
Employed since 1997
Holdings: 62,900 B shares, 19,671 employee share options



JOHAN SEDIHÑ
born: 1965

Operations & IT
Employed since 1993
Holdings: 200 B shares, 14,051 employee share options



JOSEPH K JACHINOWSKI
born: 1955

Product Creation
Employed since 2005 (founded IMPAC in 1990)
Holdings: —



HÅKAN BERGSTRÖM
born: 1956

Finance & Control
Employed since 2001
Holdings: 11,671 B shares, 19,671 employee share options



SVERKER GLANS
born: 1944

Quality & Regulatory Affairs
Employed since 1993
Holdings: 16,613 B shares, 19,671 employee share options



VOLKER STIEBER
born: 1943

Research & Academic Relations
Employed since 1997
Holdings: 20,000 B shares, 23,184 employee share options



ÅSA THUNMAN
born: 1969

Legal
Employed since 1999
Holdings: 200 B shares, 14,051 employee share options



KARIN ISBERG
born: 1959

Human Resources
Employed since 2004
Holdings: 200 B shares, 14,051 employee share options



PETER EJEMYR
born: 1964

Corporate Communications
Employed since 2003
Holdings: 200 B shares, 14,051 employee share options

Group's accounting principles.

At the Annual General Meeting on September 21, 2004, Deloitte & Touche AB was elected as the auditor of Elekta AB with Lars Svantemark as senior auditor. The election of auditor was proposed by the Nomination Committee and preceded by a tender process.

Deloitte & Touche AB has been the auditor of Elekta AB since 2002.

Lars Svantemark, born 1949 and authorized public accountant, has been senior auditor in Elekta since 2000. In addition to Elekta, Lars Svantemark's auditing assignments include Poolia, My Travel, Sita, the Nicator Group and CVC Capital Partners. He also has experience as auditor of Sandvik and A-Com and has no auditing assignments in companies related to Elekta's major owners or its President. The auditors' fees during the fiscal year are reported in Note 25.

Financial reporting and information

Elekta provides the market with continuous information regarding the company's development and financial position. In 2004, the Board of Directors adopted an information policy in accordance with the requirements stipulated in the listing agreement with the Stockholm Stock Exchange.

Financial information is published regularly in the form of:

- Interim reports, which are published as press releases
- Elekta's annual report
- Press releases on news and events that may significantly affect the company's valuation and future prospects
- Presentations and telephone conferences for financial analysts, investors and media shortly after the publication of interim and year-end reports or other important information

- Capital markets days arranged by the company at one of its major units and in conjunction with major scientific conferences where Elekta is exhibiting
- Presentations for financial analysts and investors at various places around the world
- Elekta's website - www.elekta.com - where the above information is made available

Swedish Code of Corporate Governance

As a company listed on the A-list of the Stockholm Stock Exchange, Elekta is subject to the Swedish Code of Corporate Governance. Elekta strives to comply with this code and, in accordance with the Stockholm Stock Exchange's requirements, will implement the code not later than to the 2006 Annual General Meeting. During the 2005/06 fiscal year, projects will be conducted to ensure that Elekta meets the code's requirements or to identify motivated divergences.

Income statement

SEK M	Note	GROUP		PARENT COMPANY	
		2004/05	2003/04	2004/05	2003/04
Net sales	3	3,152	2,900	—	—
Cost of products sold		-1,948	-1,783	—	—
Gross profit		1,204	1,117	—	—
Selling expenses		-408	-375	—	—
Administrative expenses		-285	-291	-45	-65
R&D expenses		-235	-218	—	—
Currency exchange differences in operations		73	73	—	—
Operating profit/loss	4, 22-25	349	306	-45	-65
Income from participations in Group companies	5	—	—	50	54
Income from participations in associated companies	6	7	8	—	-5
Interest income	7	22	27	27	34
Interest costs and similar profit/loss items	7	-15	-16	-9	-10
Financial currency exchange differences		0	0	16	14
Profit after financial items		363	325	39	22
Appropriations	8	—	—	-10	-7
Taxes	9	-122	-77	-8	-6
PROFIT FOR THE YEAR		241	248	21	9
Earnings per share before dilution, SEK		7.69	7.63		
Earnings per share after dilution, SEK		7.67	7.63		
Average number of shares before dilution, 000s		31,330	32,585		
Average number of shares after dilution, 000s		31,394	32,585		

Comments on the income statement

Net sales

The Group's net sales increased by 9 percent to SEK 3,152 M (2,900), with IMPAC accounting for SEK 47 M. Based on unchanged exchange rates, net sales increased by 13 percent, in line with Elekta's financial objective of 10 to 15 percent growth. The number of delivered linear accelerators and Leksell Gamma Knife® units increased during the year. Net sales in the after-market increased by 4 percent to SEK 937 M (900) and accounted for 30 percent (31) of consolidated net sales.

Earnings

Operating profit rose by 14 percent to SEK 349 M (306), mainly through an increase in sales volume. Exchange rate movements compared with the year-earlier period had a negative effect of approx. SEK 61 M on operating profit, primarily through a strengthening of the GBP and a weakening of the USD against the SEK. The operating margin was 11 percent (11).

The gross margin declined to 38 percent (39) as a result of a changed product mix.

Elekta's products within neurosurgery are produced on subcontract in Sweden, while the most important products within oncology are assembled and tested in the company's own facilities in the UK.

Purchasing of products, materials and consumables comprises the largest single cost item, accounting for 45 percent of the Group's total operating expenses. The second largest item is personnel costs, at 30 percent.

Investments in research and development increased by 10 percent to SEK 230 M (210), corresponding to 7 percent (7) of net sales. Capitalization of development costs and amortization

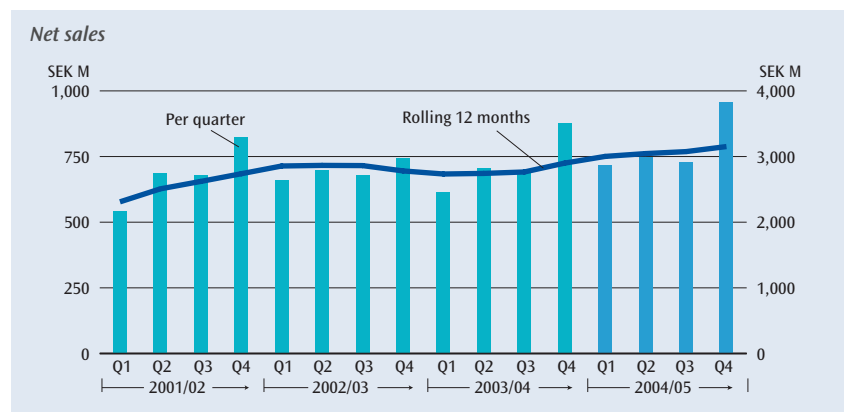

	Net sales, SEK M	Change, %	Operating profit/loss, SEK M	Operating margin, %
Q1	717	17	75	10
Q2	749	6	91	12
Q3	730	4	70	10
Q4	956	9	113	12
Full year 2004/05	3,152	9	349	11

of capitalized development costs had a negative effect of SEK 5 M (neg: 8). SEK 16 M (8) was capitalized and SEK 21 M (16) was amortized.

Elekta hedges part of the net exposure per currency over a rolling 24-month period. Currency gains on forward contracts amounted to SEK 64 M (95). The unrealized exchange rate gain from forward contracts that was not included in the balance sheet was SEK 14 M.

Net interest weakened to SEK 7 M (11) as a result of lower interest income.

Profit after net financial items improved by SEK 38 M to SEK 363 M (325).

Tax expenses on profits for the year amounted to SEK 122 M, or 34 percent. Tax expenses for fiscal 2003/04 were positively affected by adjustment of taxes for previous years. SEK 56 M (24) of tax expenses was deferred tax.

Profit for the fiscal year amounted to SEK 248 M (234).

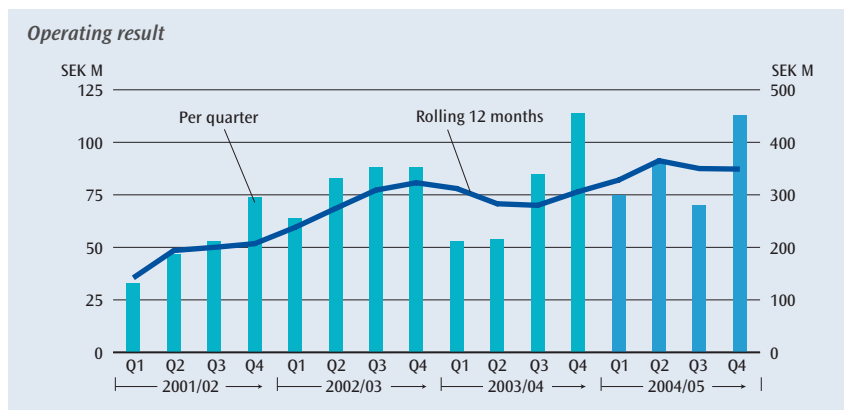

Balance sheet

SEK M	Note	GROUP		PARENT COMPANY	
		April 30, 2004	April 30, 2005	April 30, 2005	April 30, 2004
Intangible fixed assets	10	1,895	372	—	—
Tangible fixed assets	11	189	134	—	—
Financial fixed assets	12	22	16	1,886	970
Total fixed assets		2,106	522	1,886	970
Inventories	13	362	311	—	—
Deferred tax assets	9	36	84	5	4
Receivables	14	1,230	1,008	533	193
Current investments	15	—	155	—	155
Cash and bank		744	996	192	217
Total current assets		2,372	2,554	730	569
TOTAL ASSETS	3	4,478	3,076	2,616	1,539
Share capital		158	155	158	155
Restricted reserves		369	267	169	98
Unrestricted reserves		906	743	851	892
Profit for the year		241	248	21	9
Total shareholders' equity	16	1,674	1,413	1,199	1,154
Untaxed reserves	8	—	—	17	7
Deferred tax liabilities	9	164	40	—	—
Other provisions	17	117	118	6	7
Total provisions		281	158	6	7
Interest-bearing liabilities	18	833	231	881	273
Interest-free liabilities	19	1,690	1,274	513	98
Total liabilities		2,523	1,505	1,394	371
TOTAL SHAREHOLDERS' EQUITY, PROVISIONS AND LIABILITIES		4,478	3,076	2,616	1,539
Assets pledged	20	54	76	43	42
Contingent liabilities	21	151	109	326	217

Comments on the balance sheet

Assets and capital employed

The Group's total assets increased by SEK 1,402 M to SEK 4,478 M (3,076). The acquisition of IMPAC sharply changed Elekta's balance sheet, which is shown in the specification under the cash flow statement on page 44.

At the end of the fiscal year, the Group's fixed assets amounted to SEK 2,106 M (522). Intangible fixed assets increased by SEK 1,523 M. The acquisition of IMPAC increased goodwill by SEK 1,053 M and other intangible fixed assets by SEK 515 M.

Current assets excluding liquid funds rose by SEK 225 M to SEK 1,628 M (1,403).

Liquid funds declined by SEK 407 M to SEK 744 M (1,151) and amounted to SEK 17 percent (37) of the total assets at the end of the fiscal year. Of the Group's bank deposits, SEK 52 M (76) was pledged, primarily for commercial guarantees.

The value in SEK of the Group's net foreign assets amounted to SEK 1,075 M (757).

The Group's capital employed increased to SEK 2,507 M (1,644). The capital turnover ratio was 0.9 (0.9).

Earnings ratio

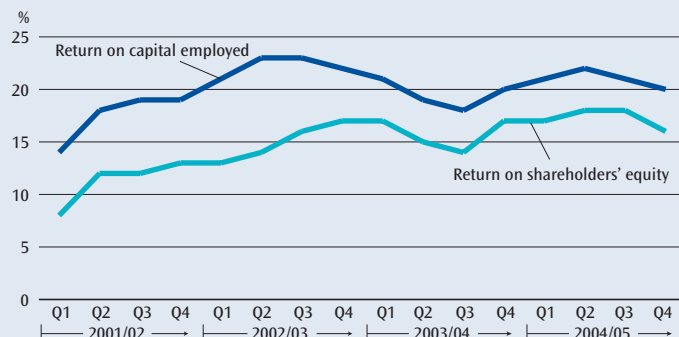

Liabilities and shareholders' equity

To finance the acquisition of IMPAC, a five-year revolving credit facility of USD 125 M was raised during the year. On April 30, 2005, USD 88 M was outstanding under the facility. IMPAC was acquired such a short time before fiscal year-end that the liquidity had not been fully integrated by then. For this reason, both liquid funds and loans were higher than would be expected in a normal situation. Interest-bearing liabilities increased by SEK 602 M to SEK 833 M (231). The net loan debt amounted to SEK 89 M.

Interest-free liabilities rose by SEK 416 M, primarily as a result of increased advance payments from customers and deferred income. Provisions increased by SEK 123 M, including deferred tax liabilities of SEK 124 M. Operating liabilities exceeded operating receivables by SEK 343 M (29).

Shareholders' equity amounted to SEK 1,674 M (1,413).

The Group's equity/assets ratio was 37 percent and the net debt/equity ratio was 0.05.

Return on shareholders' equity amounted to 16 percent (17), while return on capital employed was 20 percent (20).

Changes in shareholders' equity

Group, SEK M	Share capital	Restricted reserves	Unrestricted reserves		Total
Opening balance May 1, 2003	161	200	1,084		1,445
Exercise of warrants	4	22	—		26
Redemption of shares	-10	—	-302		-312
Translation difference	—	—	-8		-8
Translation differences on hedging instruments	—	—	14		14
Transfer between restricted and unrestricted equity	—	45	-45		0
Profit for the year	—	—	248		248
Closing balance April 30, 2004	155	267	991		1,413
Changed accounting principle	—	—	-2		-2
Exercise of warrants	3	71	—		74
Repurchase of shares	—	—	-50		-50
Translation difference	—	—	-18		-18
Translation differences on hedging instruments	—	—	16		16
Transfer between restricted and unrestricted equity	—	31	-31		0
Profit for the year	—	—	241		241
Closing balance April 30, 2005	158	369	1,147		1,674

Parent Company, SEK M	Share capital	Premium reserve	Unrestricted reserves	Retained earnings	Total
Opening balance May 1, 2003	161	76	900	266	1,403
Exercise of warrants	4	22	—	—	26
Redemption of shares	-10	—	-302	—	-312
Group contribution received after tax	—	—	—	28	28
Profit for the year	—	—	—	9	9
Closing balance April 30, 2004	155	98	598	303	1,154
Exercise of warrants	3	71	—	—	74
Repurchase of shares	—	—	-50	—	-50
Profit for the year	—	—	—	21	21
Closing balance April 30, 2005	158	169	548	324	1,199

Comments on the statement of changes in shareholders' equity

During May-September 2004, 501,200 new series B shares were subscribed through the exercise of warrants within the framework of the established option programs.

In order to fulfill the company's dividend policy, and as part of the change in Elekta's capital structure, Elekta repurchased 224,900 B series shares during January-February 2005 at an average price of SEK 222.34 and to a total value of SEK 50 M. The intent is that the shares repurchased in accordance with Elekta's dividend policy will be canceled, subject to the approval of the Annual General Meeting in September 2005.

On April 30, 2005, the total number of shares was 31,567,454.

Foreign currencies included in shareholder's equity are translated to SEK at the fiscal year-end rate. Translation differences are reported directly against consolidated shareholders' equity. Shareholders' equity in foreign currency is hedged when, after individual assessment, this is deemed appropriate. The long-term loan in USD raised in December 2002 is being used to hedge net investments in the American subsidiaries.

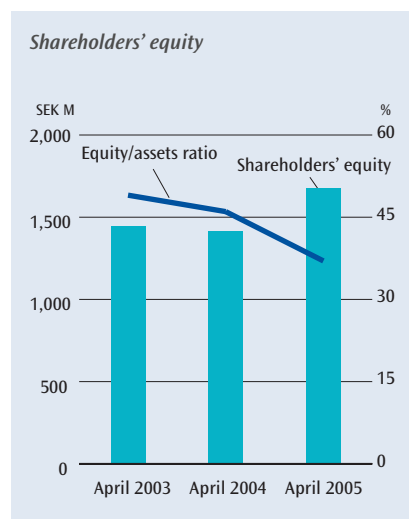
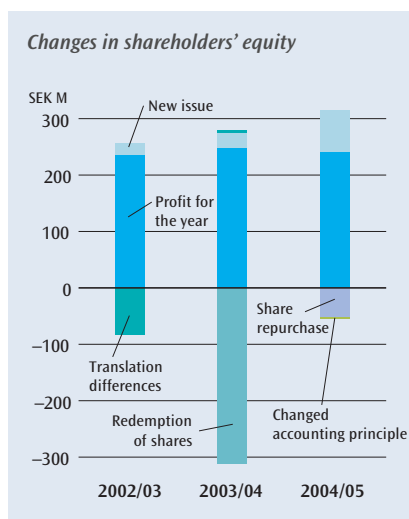

Cash flow statement

SEK M	GROUP		PARENT COMPANY	
	2004/05	2003/04	2004/05	2003/04
Profit for the year	241	248	21	9
Depreciation and writedowns charged against these results	106	88	—	—
Participation in profit/loss of associated companies, after tax	-8	-9	—	—
Result from divestments of fixed assets	—	4	—	5
Capitalized development	-16	-8	—	—
Appropriations	—	—	10	7
Taxes unpaid	97	49	8	6
Operating flow	420	372	39	27
Increase (-)/ decrease (+) in current receivables	-46	6	-340	123
Increase (-)/ decrease (+) in inventories	-55	-49	—	—
Increase (+)/ decrease (-) in interest-free liabilities	99	98	406	20
Increase (+)/ decrease (-) in provisions	-10	21	-1	7
Changes in working capital	-12	76	65	150
Cash flow from operating activities	408	448	104	177
Investments in shares and participations	-4	—	-214	-1
Repayments from partnerships	7	6	—	—
Increase (-)/ decrease (+) in long-term receivables	—	—	-702	—
Investments in intangible assets	-3	-7	—	—
Investments in machinery and equipment	-66	-84	—	—
Acquisition of subsidiary *	-1,384	—	—	—
Investments and divestments	-1,450	-85	-916	-1
CASH FLOW AFTER INVESTMENTS	-1,042	363	-812	176
Borrowings	623	—	623	—
Repayment of debt	-5	-7	-15	-22
New issues, warrant premiums, redemption of shares and group contribution	24	-295	24	-258
External financing	642	-302	632	-280
Change in liquid funds during the year excl. translation differences	-400	61	-180	-104
Translation differences on liquid funds	-7	3	—	—
Change in liquid funds during the year	-407	64	-180	-104
Liquid funds at the beginning of the year	1,151	1,087	372	476
Liquid funds at year-end	744	1,151	192	372
*Acquired operations 2004/05				
Fixed assets	1,600			
Operating assets	198			
Liquid funds	428			
Provisions	-116			
Interest-free liabilities	-298			
Purchase price paid	1,812			
Liquid funds in acquired company	-428			
Effect on Group's liquid funds	1,384			

Comments on the cash flow statement

The purpose of a cash flow statement is to describe the ability of a business to generate liquid funds. Elekta's cash flow is primarily used to finance market growth, strategic research projects and investments. Based on income statement and balance sheet items translated at average rates, the analysis shows the Group's net flows during the year.

Profit for the fiscal year, adjusted for items that did not affect cash flow, resulted in operating flow of SEK 420 M, an improvement of SEK 48 M compared with the preceding fiscal year.

Tied-up working capital increased by SEK 12 M. Cash flow from operating activities declined by SEK 40 M to SEK 408 M.

The acquisition of IMPAC affected cash flow in a negative amount of SEK 1,384 M. Cash flow from continuous investments and divestments was negative in an amount of SEK 66 M (neg: 85). Cash flow after continuous investments amounted to SEK 342 M (363).

Elekta's project-based operations affect cash flow as well as order bookings and net sales. Payment flows from projects generally occur in connection with order receipt, delivery and acceptance, generating considerable fluctuations in the amount of working capital tied up during the year.

Cash flow after continuous investments

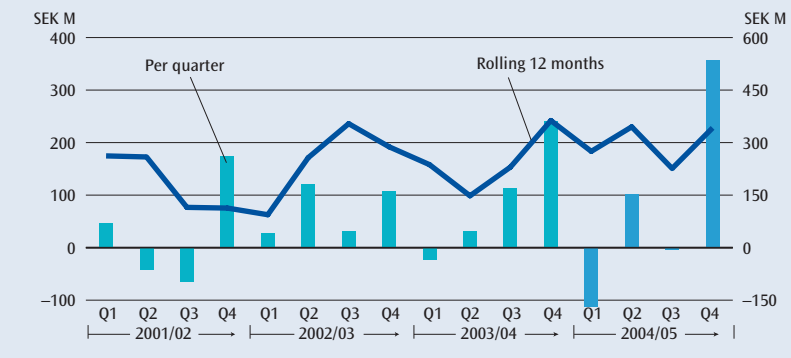

Cash flow after continuous investments

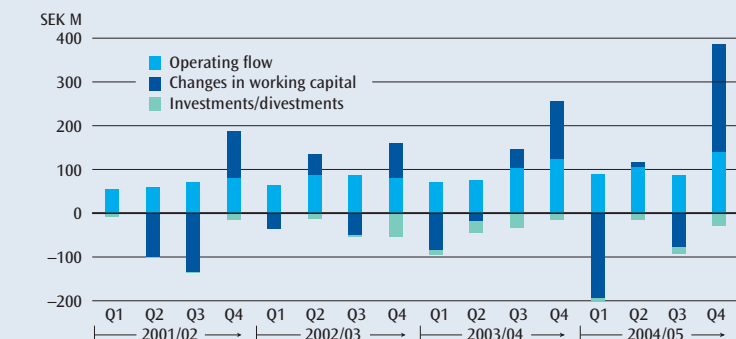

Notes

NOTE 1 ACCOUNTING PRINCIPLES

Elekta's financial statements have been prepared in accordance with the Annual Accounts Act and the recommendations and statements issued by the Swedish Financial Accounting Standards Council.

Changed accounting principle

As of the 2004/05 fiscal year, Elekta applies the Swedish Financial Accounting Standards Council's Recommendation RR29 (IAS 19) Employee Benefits. The effect of the transition is marginal. Provision for pensions rose by SEK 3 M and shareholders' equity declined by SEK 2 M.

Consolidated accounts

Elekta's financial statements include all companies in which the Parent company directly or indirectly holds more than 50 percent of the shares' voting rights as well as companies in which the Group exerts a decisive influence in another manner. The consolidated accounts have been prepared in accordance with the purchase accounting method.

Country	Currency	Average rate			Closing rate		
		May–Apr. 2004/05	May–Apr. 2003/04	Change, %	Apr. 30 2005	Apr. 30 2004	Change, %
Canada	1 CAD	5.668	5.741	–1	5.660	5.575	2
Euro	1 EUR	9.099	9.125	0	9.168	9.138	0
Great Britain	1 GBP	13.319	13.184	1	13.533	13.550	0
Hong Kong	1 HKD	0.923	0.992	–7	0.908	0.983	–8
Japan	100 JPY	6.695	6.895	–3	6.720	6.930	–3
United States	1 USD	7.196	7.717	–7	7.075	7.658	–8

The income statements and balance sheets of foreign subsidiaries have been translated in accordance with the current method. This means that all items in the income statements have been translated at the average rate for the fiscal year, while assets and liabilities in the balance sheets have been translated at the fiscal year-end rate. Translation differences have been reported directly against consolidated shareholders' equity.

Long-term financing of subsidiaries is considered to represent an increase in the Parent Company's net investment in a subsidiary. In the consolidated accounts, taking the tax effect into account, exchange gains and losses in the Parent Company have been reported against translation differences in shareholders' equity.

Associated companies

Associated company accounting is applied for share investments in companies in which the Group owns more than 20 percent and less than 50 percent of the voting rights, or otherwise has a significant influence. Associated company accounting is applied in accordance with the equity method.

Income recognition

Income from all Elekta products is recognized upon delivery of the products and significant risks and benefits associated with ownership of the products are transferred to the purchaser.

Taxes

Deferred tax is calculated and reported in accordance with the balance sheet method. In accordance with this method, deferred tax is calculated based on the difference between the taxable value and the reported value of assets and liabilities. Loss carry-forwards that arise are treated as deferred tax assets in those cases in which it is probable that these will be utilized. Valuation is based on the anticipated tax rate for the immediately following year in each country.

Reported tax expense includes current tax, changes in deferred tax receivables/liabilities and taxes on participations in the earnings of associated companies.

Intangible assets

Research and development

Research and development costs are expensed as they are incurred. In those instances in which it is difficult to distinguish between the research phase and the development phase in a project, the entire project is considered as research and is expensed on an immediate basis. Identifiable costs for the development of new products are capitalized to the extent that these are considered to provide future financial benefits. In other instances, development expenditures are expensed as they are incurred. Costs for development reported for a period in the income statement are never capitalized during future periods. Capitalized expenditures are depreciated on a straightline basis from the time when the asset begins to be used or is produced commercially and during the estimated useful life of the asset. The amortization period is 3–5 years.

Goodwill

Goodwill is defined as the value by which the acquisition price exceeds the market value of the net assets acquired by the Group in connection with a company acquisition or asset-transfer transaction.

Goodwill is amortized over a period of five years, with the exception of goodwill attributable to the acquisition in January 1997 of Philips Radiation Therapy, which is being amortized over 20 years. This acquisition is strategically important for the further development of Elekta's business in the areas of cancer treatment and neurosurgery. As a result of the acquisition, Elekta is the only company that can offer a complete range of advanced clinical solutions for both radiosurgery and radiation therapy.

Other intangible assets

Intangible assets include patents, licenses, technology, trademarks, customer relationships etc. At acquisition of such assets, the acquisition values are reported as assets, which are amortized straight-line during the estimated useful life, which varies between 5–20 years. Surplus value in acquired order backlog is also reported as other intangible asset and is amortized over one year.

Tangible assets

Tangible assets acquired by Group companies are reported at their historic acquisition value, less accumulated depreciation and any write-downs. Assets in acquired companies are reported at the market value applying on the acquisition date after deduction for subsequent accumulated depreciation. Machinery and equipment is depreciated on a straight-line basis during its economic life of between 3 and 5 years. Installations and improvements on other parties' property are depreciated during the period of the lease agreement.

Leasing

The leasing of fixed assets, for which the Group is essentially responsible for the same risks and benefits as it would be in the case of direct ownership, is classified as financial leasing. The leased asset is reported as a fixed asset and the corresponding obligation to pay a leasing fee is reported as an interest-bearing liability. The leasing payments are distributed between amortization of the liability and financial expense, so that each reporting period is charged with an interest amount corresponding to a fixed interest rate on the reported liability during each period. The leased asset is depreciated in accordance with the same principles that apply to other assets of the same type. If any uncertainty exists about whether the asset will be taken over at the end of the leasing period, the asset is depreciated during the leasing period, if this is shorter.

Leasing of assets, for which the lessor, for all practical purposes, is considered the owner, is classified as operational leasing. The leasing fee is expensed on a straight-line basis over the leasing period.

NOTE 1 ACCOUNTING PRINCIPLES, CONT.

Inventories

Inventories are valued at the lower of acquisition value and fair value.

Receivables

Receivables are shown in the amounts expected to be received.

Receivables and liabilities in foreign currency and hedging

Receivables and liabilities in foreign currency are valued at fiscal year-end exchange rates.

Hedging of future flows in foreign currencies affect earnings concurrently with the reporting of the hedged receivables and liabilities in the balance sheet. Hedging transactions are then valued at the fiscal year-end exchange rate and the revaluation is shown in the operating result.

Currency loans for hedging investments in foreign net assets are valued at the fiscal year-end rate. Exchange-rate differences are eliminated from the income statement and, with tax effects taken into account, are reported directly against shareholders' equity and are thus offset against the translation differences that arise when translating the subsidiaries' balance sheets into SEK.

Liquid funds

Liquid funds comprise cash and bank balances and current investments. To a certain extent, current investments consist of interest-bearing securities with terms of more than three months. However, such investments refer to securities with high liquidity, which can easily be transformed into liquid funds.

Provisions

Provisions are reported when the Group has, or is considered to have an obligation resulting from an event that has occurred and for which a payment demand is expected to make good the obligation. A further condition is that it is possible to make a reliable estimate of the amount that will be paid.

Pensions

The greater part of Elekta's pension commitments is met through ongoing payments to authorities or other independent organizations that administer the pension plans. For these defined contribution pension plans, a pension cost is reported on a continuous basis, which is matched by the fees paid.

Elekta has defined benefit pension plans for

certain employees in a few countries. Independent actuaries calculate the sizes of the obligations each plan has and re-values the obligations of the pension plans each year. The pension costs are estimated using the so-called Projected Unit Credit Method in a way that distributes the costs over the employee's working life. These obligations are valued at the present value of the expected future payments.

Warranty reserves

Estimated costs for product guarantees are charged against operating costs in conjunction with the income recognition of the products. The estimated costs are established based on historic statistics, with known changes being taken into account in regard to product quality, repair costs and similar items.

Market value for financial assets and liabilities

The market value of financial assets and liabilities is based on current market listings at year-end. The market value of other financial assets and liabilities, in which the market value is not given, is considered to correspond to the book value.

NOTE 2 FINANCIAL RISK MANAGEMENT

As a result of its international operations, Elekta is exposed to various financial risks, such as interest and exchange rate risk.

Financial risks are handled within the framework of a finance policy established by the Board of Directors. The Group's financial risks are compiled and followed up continuously in order to ensure compliance with the finance policy.

Liquidity and financing risk

The liquidity and financing risk pertains to the risk that the Company will not be able to cover its payment obligations due to insufficient liquid funds or difficulties in obtaining external financing.

In an effort to reduce the liquidity risk, Elekta endeavors to maintain readily available funds equal to at least 10 percent of net sales. On April 30, 2005, available liquid funds amounted to SEK 692 M, equal to 22 percent of net sales. In addition Elekta had unutilized credit facilities amounting to SEK 402 M.

Interest risk

The interest risk pertains to the risk that changes in interest rates will adversely affect Elekta's earnings. The Group's policy is to normally maintain short periods of fixed interest for its investments and liabilities.

At year-end, liquid funds accounted for 17 percent (37) of the Group's total assets. Liquid

funds were invested so as to obtain a return equivalent to the interest on government securities in the Swedish money market.

On April 30, 2005, the gross loan liability amounted to SEK 833 M (231), of which SEK 8 M (12) pertained to financial leases. The average fixed interest term was 123 (522) days.

Exchange rate risk

As a result of its international operations and structure, Elekta has considerable exposure to exchange rate fluctuations. This pertains to currency flows in different currencies – transaction exposure – and the translation of foreign subsidiaries' profits and net assets into SEK – translation exposure.

Transaction exposure

The Group's products are sold mainly in USD, EUR and JPY. Its costs are mainly in GBP and SEK. The sales companies' revenues and expenses are in local currencies. The proportion of invoiced sales in foreign currency exceeds 95 percent of the Group's total invoicing.

Elekta's policy is to hedge the exchange rate risk by using forwards or options, the extent of which is determined by the Group's estimation of the exchange rate risk in accordance with the Group's established policy. Hedging is conducted on the basis of expected net sales over a rolling 24-month

period. Hedging is carried out to reduce the effects of short-term fluctuations in currency markets. During 2004/05, exchange rate gains on forwards amounted to SEK 64 M (95). On April 30, 2005, outstanding forward contracts that were concluded in order to reduce the Group's transaction exposure corresponded to SEK 589 M, market value SEK 22 M.

The forward rate is used for the translation of hedged receivables and liabilities. The below forward contracts pertaining to sales of USD, JPY and EUR have not been revalued in the balance sheet. The unrealized exchange rate gain compared with the exchange rates on April 30, 2005 is SEK 14 M (27).

Outstanding, not revalued forwards on April 30, 2005

Currency pair	Amount	Maturity	Exchange rate
MJPY/SEK	192	7 months	6.87500
MUSD/SEK	23	2–12 months	7.18425
MEUR/SEK	5	5–12 months	9.02088
MEUR/GBP	7	4–12 months	0.71523
MUSD/GBP	21	3–15 months	1.81499

Exposure affecting Group profits

With present income and expense structure a general change of one percentage point in the value of the SEK relative to the other currencies affects Group income by approximately SEK 9 M. Forward-based hedging limits the short-term effect of exchange rate movements.

NOTE 2 FINANCIAL RISK MANAGEMENT, CONT.

The Group's net sales and operating expenses in 2004/05 are shown in the diagram to the right.

Translation exposure

The Group's consolidated earnings and shareholders' equity are exposed to changes in exchange rates. Consolidated earnings are normally not hedged. Shareholders' equity in foreign currency is hedged when, after individual assessment, it is deemed suitable. At present, the long-term loan in USD is being used to hedge net investments in the American subsidiaries.

Credit risks

Financial credit risk

Exposure occurs when surplus liquidity is invested and in the handling of the Group's financial risks. Elekta's finance policy includes special counterparty regulations in which the maximum credit exposure and the lowest credit rating for various counterparties are specified. An objective is that counterparties should have a minimum credit

Net sales and operating expenses per currency 2004/05

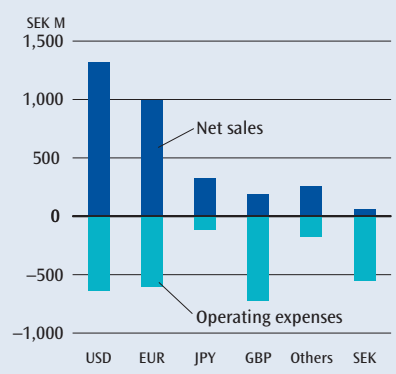

rating from Standard & Poor's/Moody's of A/A (long) and A-2/P-2 (short). Elekta invests its liquidity solely in liquid instruments with a low credit risk,

such as corporate paper with K-1 ratings and with credit worthy banks.

Credit risk in trade receivables

Trade receivables amounted to SEK 747 M (617). Provisions for expected losses are regularly assessed and amounted April 30, 2005 to SEK 26 M. Elekta's credit losses have, however, historically been low.

Customer financing

Elekta's customers often require some form of financing solution when investing in Elekta products. As the market for medical technology equipment has grown, Elekta has developed various forms of financing solutions. Elekta offers both traditional financing forms – through, for example, export credits or various leasing products – and more sophisticated “fee-for-use” arrangements. Customer financing is arranged through banks, leasing companies and other external parties, such as development banks and international aid agencies.

NOTE 3 SEGMENT REPORTING

Elekta's business operations are confined to a single operating segment, namely treatment methods for cancer and brain disorders.

This operating segment is the primary segment. The secondary segment is geographical areas. Sales figures are based on the country in which

the customer is located. Assets and investments are reported where the assets are located.

Secondary Segment

Group, SEK M	NET SALES		INVESTMENTS IN TANGIBLE AND INTANGIBLE FIXED ASSETS		ASSETS APRIL 30	
	2004/05	2003/04	2004/05	2003/04	2005	2004
Europe, Middle East, Africa	1,328	1,319	79	86	2,079	2,528
North and South America	1,057	868	4	4	2,188	338
Japan	326	303	1	2	115	135
Asia, excl. Japan	441	410	1	7	96	75
Total	3,152	2,900	85	99	4,478	3,076

NOTE 4 DEPRECIATION/AMORTIZATION

SEK M	GROUP	
	2004/05	2003/04
Cost of products sold	-47	-43
Selling expenses	-17	-11
Administrative expenses	-14	-12
R&D expenses	-28	-22
Total depreciation/amortization	-106	-88

NOTE 5 INCOME FROM PARTICIPATIONS IN GROUP COMPANIES

SEK M	PARENT COMPANY	
	2004/05	2003/04
Dividends from subsidiaries	50	65
Capital contribution to subsidiaries	—	-11
Result from participations in Group companies	50	54

NOTE 6 INCOME FROM PARTICIPATIONS IN ASSOCIATED COMPANIES

SEK M	GROUP		PARENT COMPANY	
	2004/05	2003/04	2004/05	2003/04
Income from participations in associated companies	11	8	—	—
Disposal of shares in associated company	—	-2	—	-5
Internal profit eliminations for products sold	-4	2	—	—
Result from participations in associated companies	7	8	—	-5

NOTE 7 INTEREST INCOME, INTEREST EXPENSE AND SIMILAR PROFIT/LOSS ITEMS

SEK 17 M (17) of the Parent Company's interest income of SEK 27 M (34) was received from Group companies.

Parent Company's interest expense and similar profit/loss items amounted to SEK 9 M (10), of which SEK 1 M (1) pertained to Group companies.

NOTE 8 APPROPRIATIONS AND UNTAXED RESERVES

Parent Company, SEK M	APPROPRIATIONS		UNTAXED RESERVES	
	2004/05	2003/04	2005-04-30	2004-04-30
Tax allocation reserve	-10	-7	17	7
Total	-10	-7	17	7

NOTE 9 TAXES

SEK M	GROUP		PARENT COMPANY	
	2004/05	2003/04	2004/05	2003/04
Current taxes	-67	-52	-9	-5
Deferred taxes	-56	-24	1	-1
Participations in taxes of associated companies	1	-1	—	—
Total taxes	-122	-77	-8	-6
Tax expenses:	34%	24%		
Swedish tax	28%	28%		
Effect of other tax rates for foreign companies	2%	4%		
Non-deductible amortization of goodwill	2%	2%		
Changes in tax legislation	1%	—		
Tax related to prior years	1%	-8%		
Other	0%	-2%		

Deferred tax receivables and deferred tax liabilities

Deferred tax receivables (assets) and tax liabilities in the balance sheet are attributable to the following:

Group, SEK M	April 30, 2005	Assets	Liabilities	Net
Loss carry-forwards		27	—	27
Untaxed reserves		—	-38	-38
Intangible fixed assets		7	-182	-175
Tangible fixed assets		4	-2	2
Financial fixed assets		—	-3	-3
Other assets		23	-5	18
Operating liabilities/Provisions		57	-16	41
Deferred tax assets/tax liabilities		118	-246	-128
Offsetting		-82	82	0
Net deferred tax assets/tax liabilities		36	-164	-128

NOTE 9 TAXES CONT.

Deferred tax assets/liabilities net

SEK M	Group net	Parent Company net
Opening balance May 1, 2004	44	4
Through business combination	-110	—
Adjustment for prior years	-1	—
Deferred taxes for the year	-55	1
Deferred taxes charged against shareholders' equity	-4	—
Translation differences	-2	—
Closing balance April 30, 2005	-128	5

Current tax liability

SEK M	GROUP		PARENT COMPANY	
	April 30, 2005	April 30, 2004	April 30, 2005	April 30, 2004
Opening balance	32	9	5	—
Through business combination	-4	—	—	—
Adjustment for prior years	3	1	—	—
Current tax for the year	64	51	9	5
Paid taxes	-26	-28	—	0
Translation differences	—	-1	-1	—
Closing balance	69	32	13	5

NOTE 10 INTANGIBLE FIXED ASSETS

SEK M	Capitalized development	Goodwill	Other intangible assets	Total
Acquisition value May 1, 2004	47	549	13	609
Reclassification	—	-50	50	0
Through business combination	—	1,053	515	1,568
Purchases	19	—	0	19
Sales/disposals	-31	—	-20	-51
Translation differences	0	2	1	3
Acquisition value April 30, 2005	35	1,554	559	2,148
Accumulated amortization May 1, 2004	-20	-207	-10	-237
Reclassification	—	20	-20	0
Sales/disposals	31	—	20	51
Amortization for the year	-21	-25	-21	-67
Translation differences	0	0	0	0
Accumulated amortization April 30, 2005	-10	-212	-31	-253
Residual value according to plan April 30, 2005	25	1,342	528	1,895

NOTE 11 TANGIBLE FIXED ASSETS

SEK M	Machinery etc. for production	Equipment, tools and installations	Finance lease equipment	Total
Acquisition value May 1, 2004	52	350	54	456
Reclassification	1	-1	—	0
Through business combination	—	29	—	29
Purchases	7	58	1	66
Sales/disposals	—	-8	—	-8
Translation differences	0	-3	0	-3
Acquisition value April 30, 2005	60	425	55	540
Accumulated depreciation May 1, 2004	-39	-244	-39	-322
Sales/disposals	—	8	—	8
Depreciation for the year	-4	-30	-5	-39
Translation differences	0	2	0	2
Accumulated depreciation April 30, 2005	-43	-264	-44	-351
Residual value according to plan April 30, 2005	17	161	11	189

NOTE 12 FINANCIAL FIXED ASSETS

SEK M	GROUP		PARENT COMPANY	
	April 30, 2005	April 30, 2004	April 30, 2005	April 30, 2004
Participations in Group companies	—	—	925	711
Receivables from Group companies	—	—	953	251
Participations in associated companies	13	12	8	8
Participations in other companies	2	—	—	—
Other long-term receivables	7	4	—	—
Total financial fixed assets	22	16	1,886	970

PARTICIPATIONS IN GROUP AND ASSOCIATED COMPANIES

SEK M	GROUP		PARENT COMPANY	
	Associated companies	Other companies	Associated companies	Group companies
Opening balance May 1, 2004	12	—	8	711
Reclassification	-2	2	—	—
Investments	4	—	—	214
Sales/repayments	-7	—	—	—
Participations in income of associated companies	8	—	—	—
Translation differences	-2	—	—	—
Closing balance April 30, 2005	13	2	8	925

PARTICIPATIONS IN GROUP COMPANIES

Company	Corp. reg. No.	Domicile	No. of shares and participations	Proportion of shares & votes, %	Book value, SEK M
Elekta Instrument AB	556492-0949	Stockholm, Sweden	1,000,000	100.0	50
Elekta Instrument SA	3033/1984	Geneva, Switzerland	500	100.0	57
Elekta Neuromag Oy	0756256-7	Helsinki, Finland	1,832	100.0	44
Elekta KK	65 820	Kobe, Japan	2,000	100.0	0
Elekta Holding Limited	2699176	Crawley, UK	22,810,695	100.0	276
Elekta Holdings US Inc.	58-1876545	Norcross, USA	6,020	100.0	433
Elekta Canada Inc.	R889657862	Toronto, Canada	1	100.0	0
Elekta Asia Ltd	502 493	Hong Kong	81,022,160	100.0	13
Elekta Instrument (Shanghai) Ltd		Shanghai, China		100.0	2
Elekta Pty Limited	ACN 109 006 966	Sydney, Australia	1	100.0	0
Elekta SA	B 414 404 913	Paris, France	2,500	100.0	4
Elekta Medical SA	A-818 867 31	Madrid, Spain	10,000	100.0	3
Elekta GmbH	HRB 63500	Hamburg, Germany		100.0	5
Elekta Vermögensverwaltung GmbH	HRB 56005	Hamburg, Germany		100.0	0
Elekta Kft.		Budapest, Hungary		75.0	0
Elekta GmbH	FN 166018w	Innsbruck, Austria	1	100.0	3
Elekta S.A./N.V.	HRB 613 484	Zaventem, Belgium	250	100.0	1
Elekta BV	17 097 384	Best, The Netherlands	40	100.0	0
Elekta Holding BV	33 292 546	Best, The Netherlands	40	100.0	0
Elekta S.p.A.	02723670960	Monza, Italy	500,000	100.0	34
Elekta (Pty) Ltd		Pretoria, South Africa	1	100.0	0
Total participations in Group companies					925

PARTICIPATIONS IN ASSOCIATED COMPANIES

Company	Corp. reg. No.	Domicile	No. of shares and participations	Proportion of shares & votes, %	Book value, SEK M
AB Motala Verkstad	556031-3503	Motala, Sweden	29,960	49.9	6
Miscellaneous participations					7
Total participations in associated companies					13

The book value in the Parent Company of AB Motala Verkstad is SEK 8 M.

NOTE 13 INVENTORIES

SEK M	GROUP	
	Apr. 30, 2005	Apr. 30, 2004
Components	72	52
Work in progress	94	84
Finished goods	196	175
Total inventories	362	311

NOTE 14 RECEIVABLES

SEK M	GROUP		PARENT COMPANY	
	Apr. 30, 2005	Apr. 30, 2004	Apr. 30, 2005	Apr. 30, 2004
Accounts receivable	741	609	—	—
Receivables from Group companies	—	—	526	133
Receivables from associated companies	1	1	1	1
Other receivables	76	96	0	44
Prepaid expenses and accrued income	404	292	4	13
Maturities of less than 1 year	1,222	998	531	191
Accounts receivable	6	8	—	—
Receivables from associated companies	1	2	1	2
Prepaid expenses	1	—	1	—
Maturity of more than 1 year	8	10	2	2
Total receivables	1,230	1,008	533	193

The Prepaid expenses and accrued income item in the consolidated balance sheet includes accrued income of SEK 307 M (240) for projects.

NOTE 15 CURRENT INVESTMENTS

SEK M	GROUP		PARENT COMPANY	
	Apr. 30, 2005	Apr. 30, 2004	Apr. 30, 2005	Apr. 30, 2004
Money market fund	—	155	—	155
Total current investments	—	155	—	155

NOTE 16 SHAREHOLDERS' EQUITY

Translation differences in the Group Shareholders' Equity

SEK M	Apr. 30, 2005	Apr. 30, 2004
Opening balance	11	5
Translation differences for the year	-2	6
Closing balance	9	11

Number of shares in Elekta AB (publ)	Series A shares	Series B shares	Total
Number of shares May 1, 2003	1,187,500	31,068,342	32,255,842
Exercise of warrants		698,125	698,125
Redemption of shares		-1,887,713	-1,887,713
Number of shares April 30, 2004	1,187,500	29,878,754	31,066,254
Exercise of warrants		501,200	501,200
Number of shares April 30, 2005	1,187,500	30,379,954	31,567,454

The par value of the share is SEK 5. One Series A share entitles the holder to 10 votes and one Series B share to one vote.

With the aim of fulfilling the company's dividend policy, Elekta repurchased 224,900 Series B shares.

The intention is that they will be cancelled subject to a decision by the Annual General Meeting to be held in September 2005.

For additional information on the Elekta share, see pages 62-64.

NOTE 17 OTHER PROVISIONS

SEK M	GROUP		PARENT COMPANY	
	Apr. 30, 2005	Apr. 30, 2004	Apr. 30, 2005	Apr. 30, 2004
Provision for pensions	21	23	3	7
Warranty provisions	64	64	—	—
Other provisions	32	31	3	—
Total other provisions	117	118	6	7

Elekta has defined benefit pension plans for certain employees in a few countries. Most common is however defined contribution plans.

Pension costs, defined benefit pension plans

SEK M	Apr. 30, 2005	Apr. 30, 2005
Current service cost	–4	–1
Interest expense	–3	–1
Return on plan assets	0	0
Actuarial losses	–3	–2
Total pension costs defined benefit plans	–10	–4

The pension plans are funded through insurances, the funds are therefore not reported in Elektas balance sheet.

Defined benefit pension plans

SEK M	Apr. 30, 2005	Apr. 30, 2004	Apr. 30, 2005	Apr. 30, 2004
Defined benefit obligation, funded plans	60	50	24	21
Fair value of plan assets	–49	–33	–21	–14
Funded status, net	11	17	3	7
Unrecognized net actuarial gains and losses	—	–3	—	—
Provisions for pension, funded plans	11	14	3	7
Defined benefit obligation, unfunded plans	10	9	—	—
Provisions for pension, unfunded plans	10	9	—	—
Pension liability for defined benefit plans, net	21	23	3	7

Provision for pensions, net

SEK M	Apr. 30, 2005	Apr. 30, 2005
Opening balance May 1, 2004	23	7
Changed accounting principle	3	—
Pension costs	10	4
Contributions	–15	–8
Provisions for pensions, net April 30, 2005	21	3

Main actuarial assumptions

weighted average	Apr. 30, 2005
Discount rate	4.0%
Expected return on plan assets	4.5%
Future salary increases	2.8%

	Warranty provisions	Other provisions
Opening balance May 1, 2004	64	31
Provisions/reversals during the year	58	5
Provisions released during the year	–57	–4
Translation differences	–1	0
Closing balance April 30, 2005	64	32

NOTE 18 INTEREST-BEARING LIABILITIES

SEK M	GROUP		PARENT COMPANY	
	Apr. 30, 2005	Apr. 30, 2004	Apr. 30, 2005	Apr. 30, 2004
Liabilities to credit institutions	820	214	814	207
Liabilities to Group companies	—	—	67	66
Finance lease liabilities	8	12	—	—
Other interest-bearing liabilities	5	5	—	—
Total interest-bearing liabilities	833	231	881	273
Maturity term structure				
SEK M	Apr. 30, 2005	Apr. 30, 2004	Apr. 30, 2005	Apr. 30, 2004
Within 1 year	667	17	728	66
Within >1 year <5 years	166	173	153	166
After 5 years	0	41	—	41
Total	833	231	881	273
Specification per currency				
Currency	Apr. 30, 2005 Amount	Apr. 30, 2005 MSEK	Apr. 30, 2004 Amount	Apr. 30, 2004 MSEK
Pounds sterling, GBP M	0	1	0	2
Euro, EUR M	1	10	1	12
US dollars, USD M	115	815	27	210
Japanese yen, JPY M	100	7	100	7
Total		833		231
Fixed interest term for liabilities to credit institutions including effects of derivative transactions				
SEK M	Apr. 30, 2005	Apr. 30, 2004		
< 1 year	756	76		
>1 year < 2 years	—	83		
>2 years <5 years	64	55		
Total	820	214		

The interest derivatives have a market value of SEK 1 M that is not included in the accounts.

NOTE 19 INTEREST-FREE LIABILITIES

SEK M	GROUP		PARENT COMPANY	
	Apr. 30, 2005	Apr. 30, 2004	Apr. 30, 2005	Apr. 30, 2004
Advance payments by customers	469	295	—	—
Accounts payable	398	349	29	15
Liabilities to Group companies	—	—	456	64
Tax liabilities	69	32	13	5
Accrued expenses and prepaid income	695	541	14	13
Other interest-free liabilities	59	57	1	1
Total interest-free liabilities	1,690	1,274	513	98
Accrued expenses and prepaid income				
Reserve for additional project costs	137	159	—	—
Prepaid service income	273	110	—	—
Accrued commission costs	45	32	—	—
Accrued vacation pay liability	43	49	2	2
Accrued social costs	8	8	—	—
Accrued interest expense	5	3	4	2
Other items	184	180	8	9
Total	695	541	14	13

NOTE 20 ASSETS PLEDGED

SEK M	GROUP		PARENT COMPANY	
	Apr. 30, 2005	Apr. 30, 2004	Apr. 30, 2005	Apr. 30, 2004
<i>Collateral pledged for contingent liabilities:</i>				
Bank balances	52	76	43	42
Receivables	2	—	—	—
Total assets pledged	54	76	43	42

NOTE 21 CONTINGENT LIABILITIES

SEK M	GROUP		PARENT COMPANY	
	Apr. 30, 2005	Apr. 30, 2004	Apr. 30, 2005	Apr. 30, 2004
Guarantees	151	109	94	59
Guarantees for subsidiaries	—	—	232	158
Total contingent liabilities	151	109	326	217

NOTE 22 NUMBER OF EMPLOYEES

	AVERAGE NUMBER OF EMPLOYEES		OF WHOM WOMEN	
	2004/05	2003/04	2004/05	2003/04
Parent Company	16	17	8	9
Subsidiaries :				
Sweden	178	160	61	51
Australia	8	—	2	—
Belgium	7	7	1	1
England	420	388	79	73
Finland	25	25	5	6
France	35	30	4	4
Hong Kong	15	14	4	4
Italy	34	33	5	5
Japan	47	49	8	8
Canada	5	6	—	—
China	101	90	21	23
The Netherlands	17	16	2	2
Switzerland	5	4	1	1
Spain	23	22	4	5
South Africa	7	7	2	2
Germany	54	53	4	4
US	239	203	66	57
Austria	13	12	4	3
Total average number of employees	1,249	1,136	281	258

Specification men/women among Board of Directors and Executive Committee

The Board of Directors was 100 (100) percent men. The Executive Committee was 100 (100) percent men.

Absence due to illness in the Swedish companies

The total absence due to illness amounts in the Swedish companies to 4 percent, of which men 2 percent and women 7 percent.

Some 54 percent of the absences are long-term, more than 60 consecutive days.

Absence due to illness for the ages 29 years or younger, 30–49 years and 50 years or older are 1, 4 respective 5 percent.

NOTE 23 WAGES, SALARIES, OTHER REMUNERATION AND SOCIAL SECURITY COSTS

SEK M	SALARIES AND REMUNERATION TO THE BOARD AND THE PRESIDENT		SALARIES AND REMUNERATION TO OTHER EMPLOYEES	
	2004/05	2003/04	2004/05	2003/04
Parent Company	6	6	13	12
Subsidiaries:				
Sweden	2	2	86	83
Australia	—	—	3	—
Belgium	1	1	3	3
England	2	2	198	174
Finland	1	1	8	8
France	1	1	11	7
Hong Kong	3	5	14	9
Italy	1	1	12	12
Japan	2	2	34	34
Canada	—	0	3	3
China	0	0	11	9
Netherlands	1	1	10	10
Switzerland	—	—	3	2
Spain	1	1	8	9
South Africa	0	0	3	3
Germany	1	1	29	29
US	5	7	152	123
Austria	1	1	5	5
Total wages, salaries and other remunerations	28	32	606	535
Pension costs, Parent Company	4	4	3	2
Pension costs, subsidiaries	2	1	50	38
Other social security costs, Parent Company	2	2	5	4
Other social security costs, subsidiaries	4	4	106	96
Total wages, salaries, other remuneration and social security costs	40	43	770	675

Bonus payments included in the above wages, salaries and other remunerations paid to the Boards and the Presidents of subsidiaries amounted to SEK 5 M (5), and SEK 1 M (2) in the Parent Company.

OPTION PROGRAMS

During the period 1999–2001, senior executives and key personnel within the Elekta Group were annually offered participation in option programs. With the exception of the President, the Board of Directors was not included in these programs. The option programs were designed in such a manner that options for subscription of B shares (warrants) in Elekta AB (publ) were issued to a subsidiary. Employees in Sweden were offered the opportunity to acquire warrants against payment of a market-priced premium based on a valuation in accordance with the Black & Scholes model. The warrants were freely transferable and not conditional upon continued employment. Employees outside Sweden were allocated employee options free of charge, which provided entitlement to acquire the aforementioned warrants at an exercise price of SEK 0.25 per warrant. The employee options were not transferable and could not be used to acquire warrants until after a certain qualification period.

Termination of employment during the qualification period meant that employee options lapsed. The most recently issued options under these programs expired in September 2004. Thus, at the end of the year, there were no warrants or employee options outstanding that were attributable to the option programs from 1999–2001.

A new option program, Elekta AB 2004 Share Unit Plan, was introduced in the autumn of 2004, whereby employee options were issued to 50 managers and key personnel within the Elekta Group. With the exception of the President, the Board of Directors is not included in the option program. The employee options were allotted free of charge, with entitlement conditional on the receiver of the options acquiring a certain predetermined number of shares in Elekta in the market and holding these shares throughout the options' lifetime. Employee options were also conditional on meeting financial targets during 2004/05, mainly related to operating result (EBIT).

Option programs 2001/2004

Issued warrants	900,000
Expiration date	Sept. 30, 2004
Subscription price	SEK 147

Outstanding April 30, 2004

Warrants held by employees	148,000
Warrants held by subsidiary	752,000
Employee options	638,700

Outstanding April 30, 2005

Warrants held by employees	—
Warrants held by subsidiary	—
Employee options	—

Exercised during the year

Warrants held by employees	501,200
Employee options	371,000

Expired during the year

Warrants	398,800
Employee options	267,700

NOTE 23 WAGES, SALARIES, OTHER REMUNERATION AND SOCIAL SECURITY COSTS CONT.

All allotted employee options expire on July 31, 2008. Each year during the lifetime of the options, it will be possible to exercise options corresponding to one third of the number of shares earned from August 1, 2005. If an option holder ceases to be employed in the Group, any options that do not yet qualify for exercise shall lapse immediately and the remaining options will normally expire three months from the date that employment ceased. Delivery of shares under the employee option program has been secured by means of Elekta AB (publ) issuing options for subscription of 732,000 B shares (warrants) to a subsidiary. Employee options thus give the holder a formal

right to acquire warrants transferred from the subsidiary. However, the only way in which the option holder is permitted to dispose of acquired warrants is through immediate exercise for subscription of shares. The total exercise price for receiving one share amounts to SEK 195.50, SEK 9 of which is the warrant price and SEK 186.50 the subscription price for one share.

The dilution effect and the impact on earnings per share as a result of outstanding warrants issued to secure the delivery of shares in accordance with the 2004 option plan is shown in the "Data per share" table on page 64.

Share Unit Plan 2004/2008 (employee options)

Max. number of shares in accordance with options issued on allotment date	712,564
Expiration date for options	July 31, 2008
Exercise price per share	SEK 195.50
Number of shares after measurement of performance goals	558,537
Lapsed during the year (in addition to those lapsed due to failure to meet performance requirements)	—
Number of shares acquired during the year (through exercise of options)	—
Number of shares from outstanding warrants April 30, 2005	558,537

REMUNERATION TO BOARD MEMBERS AND SENIOR EXECUTIVES

Principles

In accordance with the decision at the Annual General Meeting, Board fees totaling SEK 1,380,000 were disbursed; SEK 440,000 was paid to the Board Chairman, SEK 60,000 to the Executive Compensation Committee Chairman and SEK 220,000 to each of the external Board members. In addition, a fee of SEK 30,000 was paid to the other external Board member on the company's Executive Compensation Committee.

Remuneration to the President (Laurent Leksell) and other senior executives comprises basic salary, any bonus (variable remuneration), other benefits and pension. Other senior executives refer to the executive management. Executive management comprised seven persons in 2004/05, four of whom are Swedish citizens and three are foreigners.

The distribution between basic salary and variable salary shall be in proportion to the executive's responsibility and authority. The performance-

Remuneration and other benefits during the year

SEK 000s	Basic salary	Variable remuneration	Other benefits	Pension costs	Total
President	2,587	1,430	89	3,814	7,920
Other senior executives	9,225	6,591	408	1,434	17,658
Total	11,812	8,021	497	5,248	25,578

based bonus for the President is 60 percent of his basic salary. If goals are exceeded, the bonus is maximized to 150 percent of the performance-based bonus. The performance-based bonus for the other senior executives is 40-110 percent of basic salary and is similarly maximized to 150 percent of the performance-based bonus. Variable remuneration is based on the outcome of financial and individually specified goals. Bonus paid to senior executives is not pensionable income.

Laurent Leksell will continue after May 1, 2005 as a full-time employee of the company on unchanged terms. Remuneration to the new pres-

ident (Tomas Puusepp) for the 2005/06 fiscal year includes a basic salary of SEK 2.1 M per year and a performance-based bonus of SEK 1.5 M. If the goals are surpassed, the bonus is maximized to 150 percent of the performance-based bonus. A pension provision of 35 percent of the basic salary is allotted each year.

Comments on the table above

Variable remuneration pertains to the bonus attributable to the 2004/05 fiscal year, which partly was paid out quarterly during the fiscal year and partly will be paid during 2005/06. Other benefits relate to company cars.

Bonus and options system

Elekta's annual (one-year) bonus system covers executives at Group and operational level. The executives are measured against the annual earnings of the Group and their own areas of responsibility in relation to budget and also against individually specified functional goals. If bonus goals are exceeded, the bonus is maximized to 150 percent of the performance-based bonus.

In addition, the President and other senior executives hold warrants carrying an entitlement to subscribe for shares in the company. See adjacent table.

Comments on the table

The warrants have no market value since they are not transferable. However, a theoretical value for

Program 2004/2008

	Max number of shares at time of issue	After measurement of performance goals Number of shares	Theoretical value at time of issue, SEK
President	29,578	23,184	792,893
Other senior executives	159,544	125,056	4,276,915
Total	189,122	148,240	5,069,808

the warrants has been calculated based on the Black & Scholes option pricing model, assuming a share price of SEK 188 and an expected volatility of 30 percent. The value calculated in accordance with the Black & Scholes model has been reduced by 30 percent to account for the non-transferable nature of the warrants and the risk of the war-

rants partially or wholly lapsing before the original maturity date due to employment or performance requirements not being met. The theoretical value of the warrants at the time of issue has been calculated at SEK 34.20 per share that the warrant carries entitlement.

NOTE 23 SALARY, OTHER REMUNERATION AND SOCIAL SECURITY COSTS CONT.**Pensions and severance pay***Defined-benefit pensions*

The President (Laurent Leksell) is entitled to request retirement at age 60, with remuneration corresponding to 70 percent of basic salary. The pension benefit is secured through insurance.

Defined-contribution pensions

The other senior executives who are entitled to pensions have defined-contribution pension agreements. Retirement for the senior executives who are Swedish citizens is at age 65 and in other instances in accordance with each country's statutory retirement age or by special agreement.

Severance pay

In the event that notice is served by the company, the President is entitled to severance pay of three years' salary, including pension benefits, other

remuneration during a 3-4 year period and four times his annual bonus, calculated as the average bonus paid during the most recent three-year period. In addition, the President is entitled to severance pay in the event of own notice of termination of employment as the result of certain more comprehensive ownership changes. The severance pay is irrevocable. Other senior executives have notice periods of 6-12 months.

Committees and decision process

During the year, Elekta's Executive Compensation Committee (ECC) provided the Board with recommendations regarding principles for formulating the Group's compensation system and remuneration to senior executives and senior managers. The recommendations covered formulation of the bonus system, distribution between fixed and

variable remuneration as well as the size of any salary increases. The ECC also proposed criteria for assessing the performance of senior executives and senior managers. The Board has discussed the proposals from the ECC and made decisions based on the recommendation submitted. The entire Board, excluding the President, resolved on remuneration to the President for the 2003/04 fiscal year. Elekta's ECC comprises the Board Chairman, one independent Board member and the President. The Group Vice President Human Resources participates as presenter and reporter.

Conditions and guidelines regarding the allotment of warrants under the Share Unit Plan 2004/2008 were approved at the 2004 Annual General Meeting.

NOTE 24 OPERATING LEASING

The year's leasing costs amounted to SEK 50 M (46). Contracted leasing payments total SEK 71 M for the 2005/06 fiscal year, SEK 181 M for 2006/07–2009/10, and SEK 118 M for subsequent years.

NOTE 25 FEES AND REMUNERATIONS TO AUDITORS

SEK M	GROUP		PARENT COMPANY	
	2004/05	2003/04	2004/05	2003/04
Audit fees Deloitte & Touche	6	5	1	2
Other remunerations to Deloitte & Touche	9*	1	9*	1
Total	15	6	10	3

*Other remunerations are predominantly in areas closely related to audit such as accounting and tax and review in connection with acquisition.

Appropriation of profit

Distributable shareholders' equity at the Parent Company:

Unrestricted reserve	SEK	547,960,399
Retained earnings	SEK	302,801,341
Profit for the year	SEK	20,589,283
Total	SEK	871,351,023

The Board of Directors and the President propose:

to be distributed to the shareholders,		
a dividend of SEK 6.60 per share*	SEK	208,500,296
and that the remaining amount be carried forward	SEK	662,850,727
Total	SEK	871,351,023

* The total amount distributed can change up until the record date, depending on the number of warrants utilized.



AKBAR SEDDIGH
Chairman of the Board

STOCKHOLM AUGUST 18, 2005

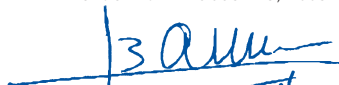

HANS BARELLA



TOMMY H KARLSSON



LAURENT LEKSELL



CARL G. PALMSTIERNA

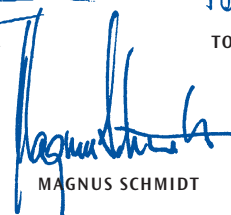

MAGNUS SCHMIDT



TOMAS PUUSEPP
President

Audit Report

To the general meeting of the shareholders of Elekta AB (publ), corporate registration number 556170-4015.

We have audited the annual accounts, the consolidated accounts, the accounting records and the administration of the Board of Directors and the President of Elekta AB (publ) for the fiscal year from May 1, 2004 to April 30, 2005. These accounts and the administration of the Company and the application of the Annual Accounts Act when preparing the annual accounts and the consolidated accounts are the responsibility of the Board of Directors and the President. Our responsibility is to express an opinion on the annual accounts, the consolidated accounts and the administration based on our audit.

We conducted our audit in accordance with generally accepted auditing standards in Sweden. Those standards require that we plan and perform the audit to obtain reasonable assurance that the annual accounts and the consolidated accounts are free of material misstate-

ment. An audit includes examining, on a test basis, evidence supporting the amounts and disclosures in the accounts. An audit also includes assessing the accounting principles used and their application by the Board of Directors and the President when preparing the annual accounts and consolidated accounts as well as evaluating the overall presentation of information in the annual accounts. As a basis for our opinion concerning discharge from liability, we examined significant decisions, actions taken and circumstances of the Company in order to be able to determine the possible liability, if any, to the Company of any Board member or the President. We also examined whether any Board member or the President has, in any other way, acted in contravention of the Companies Act, the Annual Accounts Act or the Articles of Association. We believe that our audit provides

a reasonable basis for our opinion set out below.

The annual accounts and the consolidated accounts have been prepared in accordance with the Annual Accounts Act and, thereby, give a true and fair view of the Company's and the Group's financial position and results of operations in accordance with generally accepted accounting principles in Sweden. The statutory administration report is consistent with the other parts of the annual accounts and the consolidated accounts.

We recommend to the general meeting of shareholders that the income statements and the balance sheets of the Parent Company and the Group be adopted, that the profit of the Parent Company be dealt with in accordance with the proposal in the administration report and that the members of the Board of Directors and the President be discharged from liability for the financial year.

STOCKHOLM, AUGUST 18, 2005

Deloitte & Touche AB

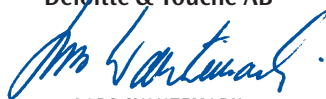

LARS SVANTEMARK
Authorized Public Accountant

Five year review, key figures and definitions

<i>Income statement</i> SEK M	2000/01*	2001/02	2002/03	2003/04	2004/05
Net sales	2,160	2,738	2,781	2,900	3,152
Operating expenses	-2,068	-2,531	-2,458	-2,594	-2,803
Operating result	92	207	323	306	349
Financial net	-23	14	-6	19	14
Profit after financial net	69	221	317	325	363
Taxes	-29	-78	-88	-77	-122
Minority	2	2	5	—	—
Profit for the year	42	145	234	248	241

<i>Cash flow</i> SEK M	2000/01	2001/02	2002/03	2003/04	2004/05
Operating flows	140	265	315	372	420
Changes in working capital	128	-128	46	76	-12
Cash flows from operating activities	268	137	361	448	408
Investments and divestments	-42	-24	-73	-85	-1,450
Cash flow after investments	226	113	288	363	-1,042

<i>Balance sheet</i> SEK M	Apr. 30, 2001*	Apr. 30, 2002	Apr. 30, 2003	Apr. 30, 2004	Apr. 30, 2005
Intangible fixed assets	415	388	408	372	1,895
Tangible fixed assets	94	87	83	134	189
Financial fixed assets	18	22	16	16	22
Inventories	224	269	258	311	362
Receivables	1,086	1,234	1,110	1,092	1,266
Liquid funds	434	536	1,087	1,151	744
Total assets	2,271	2,536	2,962	3,076	4,478
Shareholders' equity	887	1,272	1,445	1,413	1,674
Minority	8	6	0	—	0
Provisions	76	90	110	158	281
Convertible debenture loan	226	—	—	—	—
Other interest-bearing liabilities	47	35	252	231	833
Interest-free liabilities	1,027	1,133	1,155	1,274	1,690
Total shareholders' equity, provisions and liabilities	2,271	2,536	2,962	3,076	4,478

* Restated for new accounting principle for taxes.

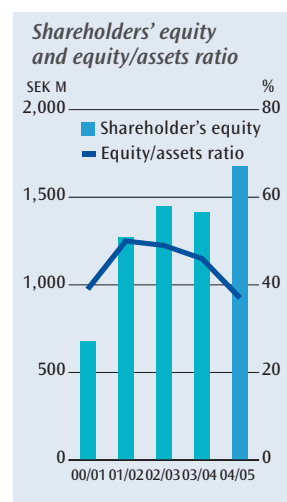
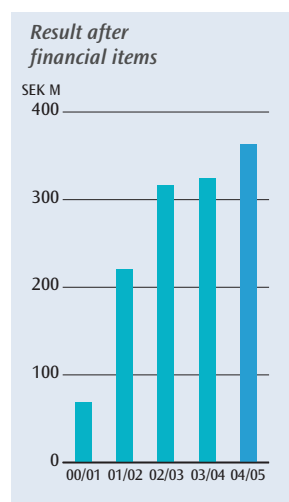
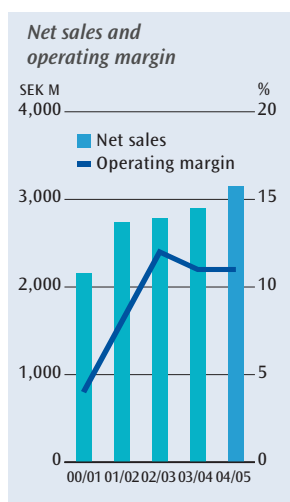
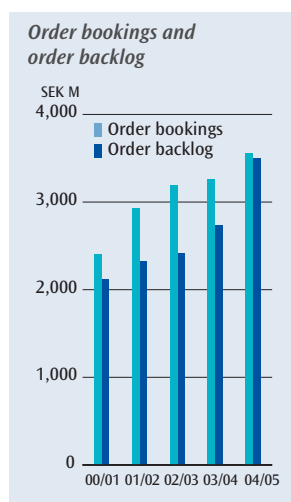

Key figures	2000/01*	2001/02	2002/03	2003/04	2004/05
Order bookings, SEK M	2,402	2,927	3,186	3,262	3,558
Order backlog, SEK M	2,112	2,317	2,411	2,728	3,493
Operating margin, %	4	8	12	11	11
Profit margin, %	3	8	11	11	12
Shareholders' equity, SEK M	887	1,272	1,445	1,413	1,674
Capital employed, SEK M	1,168	1,313	1,697	1,644	2,507
Net debt, SEK M	-161	-501	-835	-920	89
Equity/assets ratio, %	39	50	49	46	37
Net debt/equity ratio, multiple	-0.18	-0.39	-0.58	-0.65	0.05
Interest cover ratio, multiple	2.6	12.7	22.8	21.6	24.8
Return on shareholders' equity, %	5	13	17	17	16
Return on capital employed, %	10	19	22	20	20
Capital turnover ratio, multiple	1.0	1.2	1.0	0.9	0.9
Investments in tangible and intangible fixed assets, SEK M	50	32	78	99	85
Depreciation, SEK M	-74	-62	-68	-88	-106
Average number of employees	807	922	1,011	1,136	1,249

* Restated for new accounting principle for taxes.

Definitions

Operating margin Operating profit in relation to net sales.

Profit margin Profit after financial items in relation to net sales.

Capital employed Total assets less provisions and interest-free liabilities.

Equity/assets ratio Shareholders' equity including minority in relation to total assets.

Net debt Interest-bearing liabilities less liquid assets.

Net debt/equity ratio Net debt in relation to shareholders' equity including minority.

Interest cover ratio Profit after financial items plus financial expenses in relation to financial expenses.

Return on shareholders' equity Net profit for the year in relation to average shareholders' equity.

Return on capital employed Profit after financial items plus financial expenses in relation to average capital employed.

Capital turnover ratio Net sales divided by average total assets.

Average number of employees Average number of employees based on normal working hours per year.

Earning per share Net profit for the year in relation to the average number of shares.

Cash flow per share Cash flows after investments in relation to the average number of shares.

Shareholders' equity per share Shareholders' equity in relation to the number of shares at year-end.

Value added per employee Operating profit plus salaries, wages and payroll expenses divided by average number of employees.

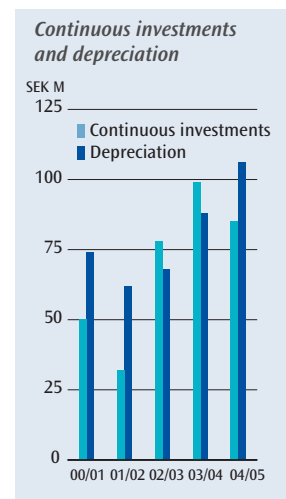
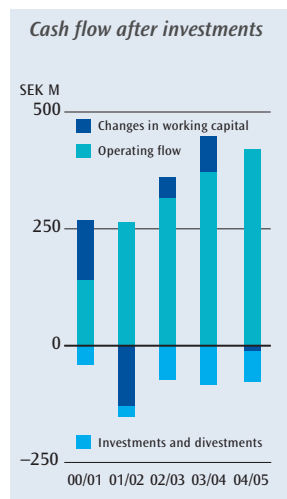
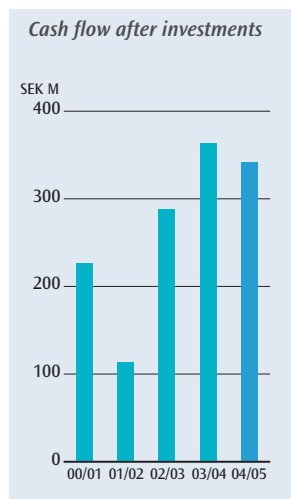
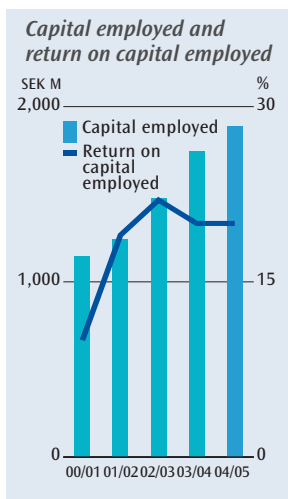

The Elekta share

As of June 30, 2005, Elekta's share capital amounts to SEK 157,837,270 distributed among 1,187,500 Series A shares and 30,379,954 Series B shares. One Series A share entitles the holder to 10 votes and Series B shares to one vote each. All shares carry equal rights to participate in the Company's assets and profits. Each share has a par value of SEK 5. In accordance with Section 13 of the Articles of Association, Series A shares are subject to right of first refusal. All Series A shares are currently owned by Laurent Leksell. At a General Meeting, each shareholder is entitled to exercise unlimited voting rights on the full number of shares that he/she owns or represents

Stock market trading

Elekta's Series B shares have been listed on the A-List of Stockholmsbörsen (Stockholm Stock Exchange) since

1994. Total trading in Elekta shares on Stockholmsbörsen during the period May 1, 2004 – April 30, 2005 amounted to 28.1 million shares (33.0), corresponding to 90 percent (101) of the total number of shares. The average number of shares traded each day during the period amounted to 111,561 (134,535). The above trading information is based on transactions reported in the SAX system, which means actual trading in Elekta shares was probably higher. Market capitalization on April 30, 2005 amounted to SEK 7,836 M (4,241).

Dividend policy

Elekta's goal is to provide shareholders with a favorable return and value growth. The goal is to distribute 20 percent or more of net profit in the form of dividends, share buy-back or comparable measures. The dividend decisions

are based on Elekta's financial position, earnings trend, growth potential and investment requirements.

Option program

A new option program, Elekta AB 2004 Share Unit Plan, was introduced in the autumn of 2004, whereby employee options were issued to 50 managers and key personnel within the Elekta Group. With the exception of the President, the Board of Directors is not included in the option program. The employee options were allotted free of charge, with entitlement conditional on the receiver of the options acquiring a certain predetermined number of shares in Elekta in the market and holding these shares throughout the options' lifetime. Employee options were also conditional on meeting financial targets during 2004/05, mainly related to operating result (EBIT). All allotted

Changes in share capital until June 30, 2005

Year	Transaction	Total number of shares	Total share capital, SEK 000s
1994	New issue	7,397,180	36,986
1994	Exercise of warrants	7,897,180	39,486
1997	New issue	9,871,475	49,357
1997	New issue	10,497,451	52,487
1999	New issue	20,994,902	104,975
2000	Offset issue	27,853,617	139,268
2001	Conversion of debentures	31,661,867	158,309
2001	Exercise of warrants	31,678,867	158,394
2002	Exercise of warrants	32,175,142	160,876
2003	Exercise of warrants	32,953,967	164,770
2004	Redemption of shares	31,066,254	155,331
2004	Exercise of warrants	31,567,454	157,837

Ownership structure June 30, 2005

Shareholding No. of shares	No. of shareholders	Percentage of shareholders	No. of shares	Percentage of share-capital	Average number per shareholders
1–500	6,587	82.7	832,302	2.6	126
501–1,000	585	7.3	468,523	1.5	801
1,001–10,000	556	7.0	1,743,558	5.5	3,136
10,001–100,000	173	2.2	5,558,377	17.6	32,129
100,001–	65	0.8	22,964,694	72.8	353,303
Total	7,966	100.0	31,567,454	100.0	3,963

Source: VPC

Warrants program 2004/2008

Warrants	558,537
Outstanding warrants June 30, 2005	558,537
Subscription period	Aug. 1, 2005 – Jul. 31, 2008
Warrant price	SEK 9.00
Subscription price	SEK 186.50

employee options expire on July 31, 2008. Each year during the lifetime of the options, it will be possible to exercise options corresponding to one third of the number of shares earned from August 1, 2005. If an option holder ceases to be employed in the Group, any options that do not yet qualify for exercise shall lapse immediately and the remaining options will normally expire three months from the date that employment ceased. Delivery of shares under the employee option program has been secured by means of Elekta AB (publ) issuing options for subscription of 732,000 B shares (warrants) to a subsidiary. Employee options thus give the holder a formal right to acquire warrants transferred from the subsidiary. However, the only way in which the option holder is permitted to dispose of acquired warrants is through immediate exercise for subscription

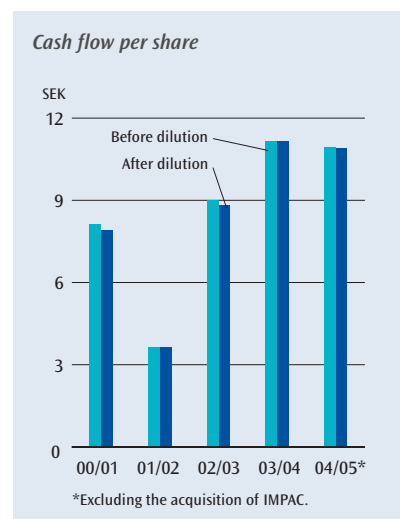
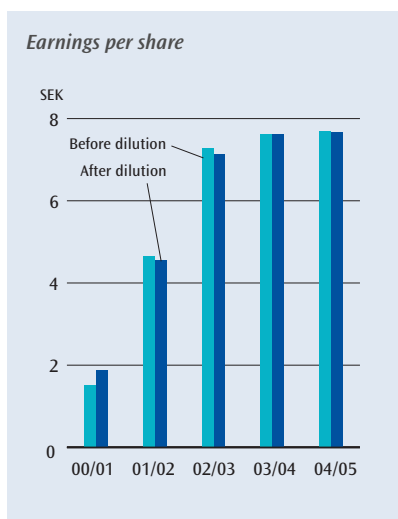

of shares. The total exercise price for receiving one share amounts to SEK 195.50, SEK 9 of which is the warrant price and SEK 186.50 the subscription price for one share.

Major shareholders June 30, 2005

Owner	No. of shares	Percentage of	
		votes	capital
Laurent Leksell with family & companies	2,444,393	31.1	7.7
Nordea Bank SA (Luxemburg)	1,534,950	3.6	4.9
Robur Aktiefonder	1,251,794	3.0	4.0
Threadneedle Investments (UK)	1,048,675	2.5	3.3
Oppenheimer fonder (USA)	700,000	1.7	2.2
SHB/SPP fonder	653,533	1.5	2.1
AMF Pension	475,000	1.1	1.5
Första AP-fonden	450,350	1.1	1.4
Carnegie fonder (Luxemburg)	442,420	1.0	1.4
Afa Försäkring	418,063	1.0	1.3
Others	22,148,276	52.4	70.2
Total	31,567,454	100.0	100.0

The table above lists the 10 largest known shareholders in Elekta AB as of June 30, 2005. The proportion of foreign ownership was approximately 61 percent. Of these shares, 73 percent of holdings were held by trustees. As a result, it is possible that there are other large shareholders with undisclosed holdings, even if no foreign shareholders have "flagged" for holdings above 5 percent. The proportion of Swedish institutional ownership was approximately 22 percent. Source: VPC

Distribution of shares June 30, 2005

Class of share	No. of shares	No. of votes	Percentage of	
			capital	votes
Series A	1,187,500	11,875,000	3.8	28.1
Series B *	30,379,954	30,379,954	96.2	71.9
Total	31,567,454	42,254,954	100.0	100.0

*of which 224,900 is repurchased by Elekta.

Distribution of shares after full exercise of warrants

Class of share	No. of shares	No. of votes	Percentage of	
			capital	votes
Series A	1,187,500	11,875,000	3.7	27.7
Series B	30,938,491	30,938,491	96.3	72.3
Total	32,125,991	42,813,491	100.0	100.0

The Elekta share

Data per share

	2000/01*	2001/02	2002/03	2003/04	2004/05
Earnings per share					
before dilution, SEK	1.52	4.66	7.29	7.63	7.69
after dilution, SEK	1.89	4.56	7.14	7.63	7.67
Cash flow per share					
before dilution, SEK	8.11	3.64	8.99	11.14	-33.26**
after dilution, SEK	7.90	3.63	8.81	11.14	-33.19**
Shareholders' equity					
before dilution, SEK	31.84	40.03	44.79	45.49	53.41
after dilution, SEK	35.03	39.89	44.58	45.49	55.90
Dividend, SEK					
	—	—	—	—	6.60
Share price, Elekta Series B, April 30, SEK					
	62.00	90.00	89.00	136.50	250.00
Market capitalization, April 30, SEK M					
	1,727	2,859	2,871	4,241	7,836
Lowest share price, SEK					
	15.50	57.00	65.00	86.00	136.00
Highest share price, SEK					
	63.00	109.50	105.50	158.00	280.00
Average number of shares					
before dilution, 000's	27,854	31,048	32,019	32,585	31,330
after dilution, 000's	31,662	32,504	32,694	32,585	31,394
Number of shares, April 30					
before dilution, 000's	27,854	31,765	32,256	31,066	31,343
after dilution, 000's	31,662	33,084	32,988	31,066	31,901

* Restated for new accounting principle for taxes

** Excluding the acquisition of IMPAC SEK 10.92 before dilution and SEK 10.89 after dilution.

Dilution 2004/05 refers to warrants program 2004/2008. Dilution 2001/02 and 2002/03 refers to warrants program 1999/2002 and 2000/2003.

The data for earlier years were not diluted by the warrants. The increase shown 2000/01 is from debentures converted 2001.

Share price trend

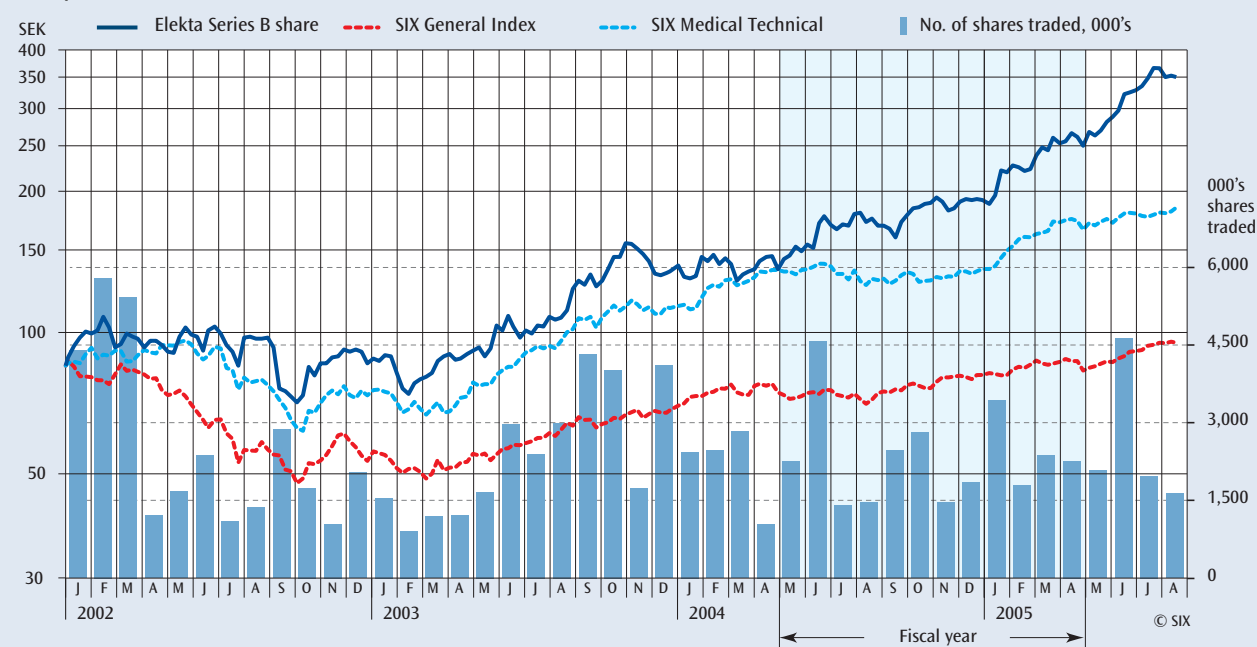

Glossary

AVM	Arteriovenous malformations – vascular malformations in the brain, which are often congenital.
Benign	A tumor or growth that is not cancerous. This means that it does not spread to other parts of the body or invade and destroy nearby tissue. The opposite of benign is malignant.
Cancer	Uncontrolled, abnormal growth of cells.
Chemotherapy	Treatment of cancer diseases with the aid of chemicals that eliminate diseased cells.
Craniopharyngioma	A benign tumor that develops near the pituitary gland
Cytotoxin	A substance having a specific toxic effect on certain cells
Computerized tomography (CT)	A radiological method of producing anatomical structures by means of layering, using computer technology.
EEG electroencephalogram	To assess brain electrical activity
Epilepsy	Disorder characterized by repeated, sudden disturbances of brain function.
Epileptogenic zones	The areas in the brain from which epileptic seizures emanates.
Fraction	Part of the total radiation dose, delivered at a daily treatment.
Functional disorders	Diseases in the central nervous system.
Magnetic resonance imaging (MRI)	Measures the difference in liquid resonance content in various parts of the body with the aid of magnetic fields.
Gamma Knife® surgery	Stereotactic radiosurgery with Leksell Gamma Knife®..
IGRT	Image guided radiation therapy
IMRT	Intensity modulated radiation therapy of cancer, where instead of than being treated with a single, large, uniform beam, the patient is treated with many very small beams; each of which can have a different intensity.
Incidence	The number of new cases of a disease in a population during a given period.
Invasive	A technique that penetrates the skin, skull, etc. The opposite of non-invasive (bloodless)..
Linear accelerator	Equipment for generating and directing ionizing radiation for treatment of cancer..
Magnetoencephalograph (MEG)	Equipment for real time mapping of the function in different parts of the brain, by measuring the magnetic field generated by brain cell activity.
Malignant	Refers to cancerous cells that usually have the ability to spread, invade, and destroy tissue. Opposite to benign.
Meningioma	A tumor arising in the meninges which surround the brain and spinal cord
Metastases	Secondary malignant tumors originating from primary cancer tumors in other parts of the body.
Multileaf collimator	An accessory to the linear accelerator, working like an aperture. With a large number of individually adjustable metal leaves, the treatment beam can be shaped to the size and shape of the target volume.
Neurology	The study of the nervous system and its disorders.
Neurosurgery	Surgery of the brain or other parts of the central nervous system.
Oncology	The study of tumor diseases.
PACS – Picture Archiving System	A storage and management system for high-resolution images
Parkinson's disease	Paralysis, with trembling and shaking as well as muscular rigidity, with a change in movements and posture by the patient.
Prevalence	The total number of cases of an illness in a population at a given time.
Positron emission tomography (PET)	A method of obtaining a layered image of organs in the body by means of emitting positrons.
Stereotaxy	A technique in which a fixed-coordinate system can determine the location of a point by specifying the coordinates in terms of height, depth and laterally.
Radiosurgery	Non-invasive surgery in which high a single doses of precise ionizing radiation replaces surgical instruments.
Radiation therapy	Fractionated ionizing radiation treatment of cancer.
Trigeminal neuralgia	Chronic facial pain, emitting from the trigeminal facial nerve.

This document is a translation of the original Swedish manuscript. If any discrepancy arises between the two versions, the content of the Swedish version takes precedence.

Design and production: Durkin Design Text: Elekta Corporate Communications Cover photo: Tobias Fischer
Print: Arkpressen, Västerås, Sweden 2005. Paper: Tom&otto Silk 300g (cover) & 150g (insert)

Readers' guide

Subject	Page
Accounting principles	46–47
Corporate governance	34–37
Currency exposure	39, 47–48
Employees	8–9, 31, 55–58
Environmental issues	33
Financial objectives	3, 7, 31
Financial risk management	47–48
IFRS transition	32–33
IMPAC	2, 12–13, 28–31, 44–45
Market regions	29
Market value	47
Production	39
Quality assurance	31
Research, development and clinical collaborations	4–5, 31
Segment reporting	48
Sensitivity analysis	30
Share repurchase	3, 32
Share split	32
Strategy	7
Taxes	39, 46, 49–50

Fighting serious disease

www.elekta.com

■ Stereotactic Neurosurgery ■ Gamma Knife® surgery ■ Functional Mapping ■ Precision Radiation Therapy ■ Image Guided Radiation Therapy ■ Stereotactic Radiation Therapy

Corporate Head Office
Stockholm, Sweden
Tel +46-8-587 254 00
Fax +46-8-587 255 00
info@elekta.com

North America
Atlanta, USA
Tel +1-770 300 9725
Fax +1-770 448 6338
info.america@elekta.com

**Europe, South America,
Africa & the Middle east**
Crawley, UK
Tel +44-1293 544 422
Fax +44-1293 654 321
info.europe@elekta.com

Japan
Kobe, Japan
Tel +81-78 241 7100
Fax +81-78 271 7823
info.japan@elekta.com

Asia Pacific
Hong Kong, China
Tel +852 2891 2208
Fax +852 2575 7133
info.asia@elekta.com